

YG-1 TOOLING SYSTEM

POWER MILLING CHUCK

- FRÄSERSPANNFUTTER
- MANDRIN PORTE FRAISE
- MANDRINI PORTA FRESA
- PORTAHERRAMIENTAS PARA FRESADO



DIN 69871-SK

HIGH-SPEED TYPE / STANDARD TYPE

DIN 69893/ISO 12164-1-HSK

HIGH-SPEED TYPE / STANDARD TYPE

CBT (BT DUAL CONTACT)

JIS B6339/MAS 403-BT

HIGH-SPEED TYPE / STANDARD TYPE

DIN 228-MTA/MTB, R8

MILLING CHUCK SET

STANDARD MILLING CHUCK SET

Q.C MILLING CHUCK SET

ACCESSORY

END MILL COLLET (K, CK, MT, JT), SPANNER

POWER MILLING CHUCK



- Rigidity is strengthened through slot made at inside milling chuck, which prevents deformation of milling chuck. Smooth cutting is achieved by maximizing end mill clamping power.
- Enough thickness of clamping part prevents chattering and ensures durability.

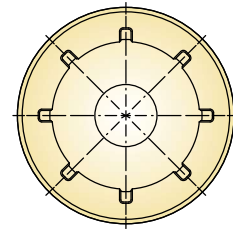

- High precision can be achieved through accurate roundness of clamping part, deburred surface and rigidity (deviation of concentricity : below 2, roughness : below RZ B1.0~1.5)
- Maintaining T.I.R not exceeding 0.01mm at 3D from nose part

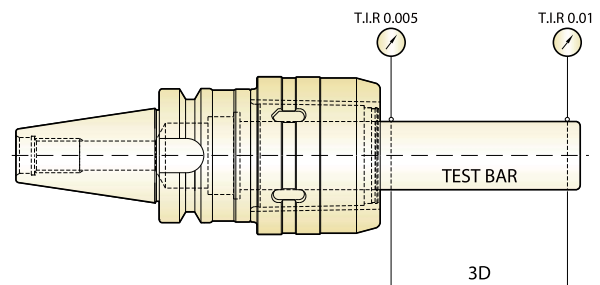

- 160% more of bearings are used in needle roller than other make's chucks, which provides strong clamping power and high durability by dispersing surface pressure even in case strong load is applied.

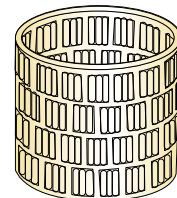

- In order to improve durability, YG-1 milling chuck is passed through following processes.
 - "Normalizing" treatment for unifying material composition and removal internal stress.
 - Ultralow temperature (-90°C) treatment called "Sub-Zero treatment" after carburizing heat treatment for prior removal of any deformation of milling chuck after use for long periods of time.

High-Speed POWER MILLING CHUCK

- Achieving optimum cutting for High-Speed heavy duty cutting and finishing with strong torque power
- Perfect clamping from 3mm depth of I.D entrance
- Achieving stability when exchanging and setting tools by stable fastening and unfastening torque



Strong Torque Power

Milling chuck (I.D)	Standard	Tolerance (Taper shank)	Run-out	Clamping torque
C20	AT3	ISO 30 (0~+0.002) ISO 40 (0~+0.003) ISO 50 (0~+0.004)	0.01mm at 3D	980Nm
C25				1,760Nm
C32				3,430Nm
C42				4,900Nm

HIGH-SPEED POWER MILLING CHUCK

DIN 69871-SK

HOCHGESCHWINDIGKEITS FRÄSERFUTTER
 MANDRIN PORTE FRAISE À GRANDE VITESSE
 MANDRINI PORTA FRESA PER ALTA VELOCITÀ
 PORTAHERRAMIENTAS PARA FRESADO DE ALTA VELOCIDAD

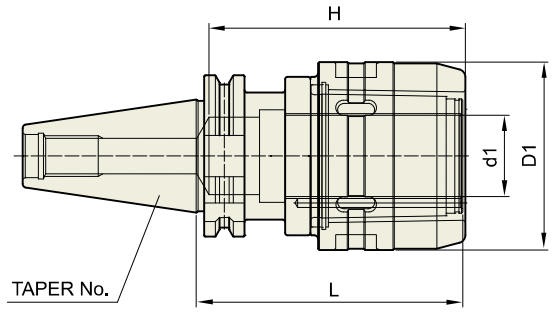

							Unit : mm
TAPER No.	MODEL No.	EDP No.	d1	D1	L	H	WEIGHT (kg)
30	SK30-C20-80HS	P2773005	20	54	80	70	1.15
	SK30-C25-80HS	P2773006	25	62.5	70	80	1.48
40	SK40-C20-105HS	P2526022	20	54	105	70	1.77
	SK40-C25-105HS	P2773001	25	62.5	105	80	2.10
	SK40-C32-105HS	P2526023	32	74	105	100	2.40
	SK40-C32-135HS	P2773007	32	74	135	100	3.10
	SK50-C20-105HS	P2773002	20	54	105	70	3.40
50	SK50-C25-105HS	P2773003	25	62.5	105	80	3.80
	SK50-C32-105HS	P2773004	32	74	105	100	4.30
	SK50-C32-135HS	P2526024	32	74	135	100	4.90
	SK50-C32-165HS	P2526025	32	74	165	100	5.60
	SK50-C42-115HS	P2773008	42	92	115	110	4.60
	SK50-C42-135HS	P2773009	42	92	135	110	5.60
	SK50-C42-165HS	P2773010	42	92	165	110	6.10

▶ CAT(ANSI B5.50) taper and Inch type products are available.



POWER MILLING CHUCK

DIN 69871-SK

FRÄSERSPANNFUTTER
MANDRIN PORTE FRAISE
MANDRINI PORTA FRESA
PORTAHERRAMIENTAS PARA FRESADO

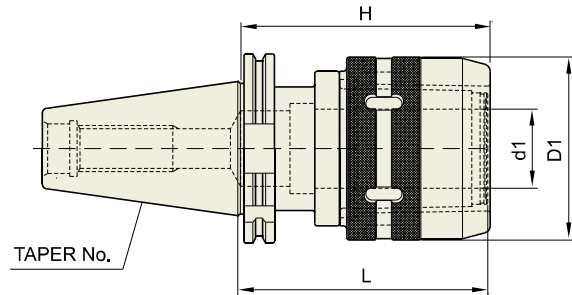

◆ STUB

Unit : mm

TAPER No.	MODEL No.	EDP No.	d1	D1	L	H	WEIGHT (kg)
30	SK30-C20-80	P2526001	20	54	80	70	1.15
	SK30-C25-80	P2526002	25	62.5	70	80	1.48
40	SK40-C20-90	P2526003	20	54	90	70	1.60
	SK40-C32-90	P2526004	32	72	90	100	2.00
50	SK50-C20-80	P2526005	20	54	80	70	3.22
	SK50-C25-90	P2526006	25	62.5	90	80	3.61
	SK50-C32-90	P2526007	32	72	90	100	3.87

◆ STANDARD

Unit : mm

TAPER No.	MODEL No.	EDP No.	d1	D1	L	H	WEIGHT (kg)
40	SK40-C20-105	P2526008	20	54	105	70	1.77
	SK40-C25-105	P2526009	25	62.5	105	80	2.01
	SK40-C32-105	P2526010	32	72	105	100	2.42
50	SK50-C20-105	P2526011	20	54	105	70	3.39
	SK50-C25-105	P2526012	25	62.5	105	80	3.78
	SK50-C32-105	P2526013	32	72	105	100	4.31
	SK50-C42-115	P2526014	42	92	115	110	4.53

◆ EXTENDED

Unit : mm

TAPER No.	MODEL No.	EDP No.	d1	D1	L	H	WEIGHT (kg)
40	SK40-C32-135	P2526015	32	72	135	100	3.11
50	SK50-C32-135	P2526018	32	72	135	100	4.94
	SK50-C42-135	P2526017	42	92	135	110	5.62

◆ EXTRA EXTENDED

Unit : mm

TAPER No.	MODEL No.	EDP No.	d1	D1	L	H	WEIGHT (kg)
50	SK50-C32-165	P2526020	32	72	165	100	5.59
	SK50-C42-165	P2526016	42	92	165	110	6.10

▶ CAT(ANSI B5.50) taper and Inch type products are available.

HYDRAULIC CHUCK

SHRINK FIT HOLDER

ER COLLET CHUCK

END MILL HOLDER & SIDE LOCK ARBOR

SHELL MILL ARBOR

POWER MILLING CHUCK

MORSE TAPER ARBOR

SK SLIM CHUCK

SYNCHRO TAPPING CHUCK

ONE STEP TAPPING CHUCK

TAPPING ER CHUCK

TAPPING CHUCK

FACE MILL ARBOR

COPY MILL ARBOR & INDEXABLE DRILL HOLDER

NC DRILL CHUCK & OTHER TOOL HOLDERS

BORING SYSTEM

ACCESSORY & OTHERS

HIGH-SPEED POWER MILLING CHUCK

**DIN 69893/
ISO 12164-1-HSK FORM A**

HOCHGESCHWINDIGKEITS FRÄSERFUTTER
MANDRIN PORTE FRAISE À GRANDE VITESSE
MANDRINI PORTA FRESA PER ALTA VELOCITÀ
PORTAHERRAMIENTAS PARA FRESADO DE ALTA VELOCIDAD

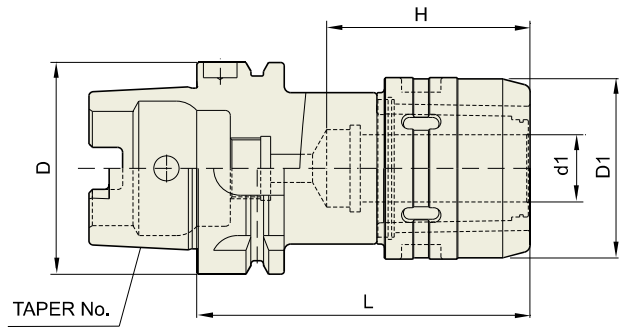

DIN 69893-HSK **6.3G** **20,000 RPM** **AD**

Collet, spanner
Refer to page 176

							Unit : mm	
TAPER No.	MODEL No.	EDP No.	d1	D1	L	H	WEIGHT (kg)	
50A	HSK50A-C20-100HS	P2773102	20	54	100	70	1.30	
63A	HSK63A-C20-105HS	P2562016	20	54	105	70	1.50	
	HSK63A-C25-120HS	P2773103	25	62.5	120	80	2.20	
	HSK63A-C32-130HS	P2562017	32	74	130	100	2.70	
100A	HSK100A-C20-110HS	P2773104	20	54	110	70	3.50	
	HSK100A-C25-130HS	P2773105	25	62.5	130	80	3.80	
	HSK100A-C32-135HS	P2773101	32	74	135	100	4.20	
	HSK100A-C42-135HS	P2773106	42	74	135	100	5.30	

▶ CAT(ANSI B5.50) taper and Inch type products are available.

- HYDRAULIC CHUCK
- SHRINK FIT HOLDER
- ER COLLET CHUCK
- END MILL HOLDER & SIDE LOCK ARBOR
- SHELL MILL ARBOR
- POWER MILLING CHUCK**
- MORSE TAPER ARBOR
- SK SLIM CHUCK
- SYNCHRO TAPPING CHUCK
- ONE STEP TAPPING CHUCK
- TAPPING ER CHUCK
- TAPPING CHUCK
- FACE MILL ARBOR
- COPY MILL ARBOR & INDEXABLE DRILL HOLDER
- NC DRILL CHUCK & OTHER TOOL HOLDERS
- BORING SYSTEM
- ACCESSORY & OTHERS



POWER MILLING CHUCK

DIN 69893/
ISO 12164-1-HSK FORM A

FRÄSERSPANNFUTTER
MANDRIN PORTE FRAISE
MANDRINI PORTA FRESA
PORTAHERRAMIENTAS PARA FRESADO

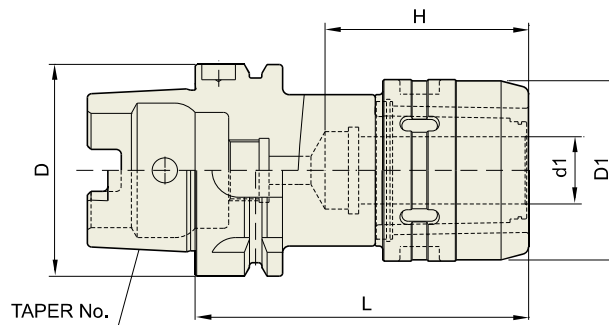

								Unit : mm
TAPER No.	MODEL No.	EDP No.	d1	D	D1	L	H	WEIGHT (kg)
50A	HSK50A-C20-100	P2773151	20	50	54	100	70	1.30
63A	HSK63A-C20-105	P2773152	20	63	54	105	70	1.50
	HSK63A-C32-130	P2600032	32	63	72	130	100	2.70
100A	HSK100A-C20-110	P2773153	20	100	54	110	70	3.50
	HSK100A-C32-135	P2773154	32	100	72	135	100	4.20
	HSK100A-C42-135	P2773155	42	100	92	135	100	5.30

◆ ACCESSORY

END MILL COLLET	MODEL No.
	K20-6, 8, 10, 12, 16
	K32-6, 8, 10, 12, 16, 20, 25
	K42-6, 8, 10, 12, 16, 20, 25, 32

► Special size of Ø3, Ø4 or Ø5 can be produced and supplied upon request.

END MILL COLLET	MODEL No.
	CK20-6, 8, 10, 12, 16
	CK25-6, 8, 10, 12, 16, 20
	CK32-6, 8, 10, 12, 16, 20, 25
	CK42-6, 8, 10, 12, 16, 20, 25, 32

SPANNER	MODEL No.
	C20 SP
	C25 SP
	C32 SP
	C42 SP

HYDRAULIC CHUCK

SHRINK FIT HOLDER

ER COLLET CHUCK

END MILL HOLDER & SIDE LOCK ARBOR

SHELL MILL ARBOR

POWER MILLING CHUCK

MORSE TAPER ARBOR

SK SLIM CHUCK

SYNCHRO TAPPING CHUCK

ONE STEP TAPPING CHUCK

TAPPING ER CHUCK

TAPPING CHUCK

FACE MILL ARBOR

COPY MILL ARBOR & INDEXABLE DRILL HOLDER

NC DRILL CHUCK & OTHER TOOL HOLDERS

BORING SYSTEM

ACCESSORY & OTHERS

HIGH-SPEED POWER MILLING CHUCK

CBT (BT DUAL CONTACT)

HOCHGESCHWINDIGKEITS FRÄSERFUTTER
 MANDRIN PORTE FRAISE À GRANDE VITESSE
 MANDRINI PORTA FRESA PER ALTA VELOCITÀ
 PORTAHERRAMIENTAS PARA FRESADO DE ALTA VELOCIDAD

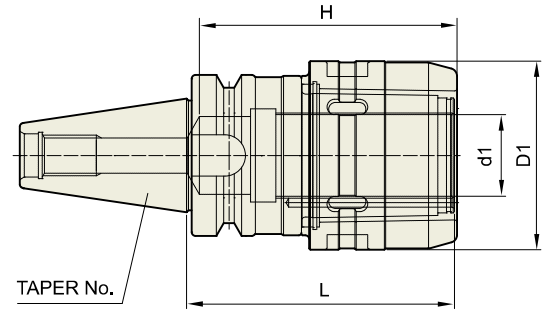

Unit : mm

TAPER No.	MODEL No.	EDP No.	d1	D1	L	H	WEIGHT (kg)
30	CBT30-C20-75HS	P2773251	20	54	75	70	1.50
	CBT30-C25-80HS	P2773252	25	62.5	80	70	2.00
40	CBT40-C20-80HS	P2773253	20	54	80	70	2.00
	CBT40-C20-105HS	P2773254	20	54	105	70	2.10
	CBT40-C25-105HS	P2773255	25	62.5	105	80	2.50
	CBT40-C32-90HS	P2773256	32	74	90	100	3.00
	CBT40-C32-105HS	P2773257	32	74	105	100	3.10
	CBT40-C32-135HS	P2773258	32	74	135	100	3.30
50	CBT50-C20-105HS	P2773259	20	54	105	70	4.50
	CBT50-C20-135HS	P2773260	20	54	135	70	4.90
	CBT50-C20-165HS	P2773261	20	54	165	70	5.40
	CBT50-C25-105HS	P2773262	25	62.5	105	80	5.20
	CBT50-C25-135HS	P2773263	25	62.5	135	80	5.80
	CBT50-C25-165HS	P2773264	25	62.5	165	80	6.20
	CBT50-C32-105HS	P2773265	32	74	105	100	6.00
	CBT50-C32-135HS	P2773266	32	74	135	100	6.70
	CBT50-C32-165HS	P2773267	32	74	165	100	7.40
	CBT50-C42-115HS	P2773268	42	92	115	110	6.70
CBT50-C42-135HS	P2773269	42	92	135	110	7.60	
CBT50-C42-165HS	P2773270	42	92	165	110	8.30	



POWER MILLING CHUCK

C

POWER MILLING CHUCK

FRÄSERSPANNFUTTER
MANDRIN PORTE FRAISE
MANDRINI PORTA FRESA
PORTAHERRAMIENTAS PARA FRESADO

**CBT
(BT DUAL CONTACT)**

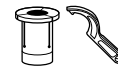
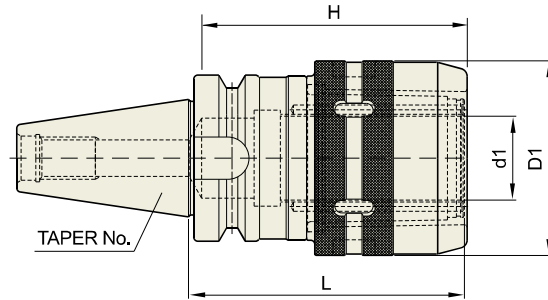

Collet, spanner
Refer to page 176

Unit : mm

TAPER No.	MODEL No.	EDP No.	d1	D1	L	H	WEIGHT (kg)
30	CBT30-C20-75	P2773204	20	54	75	70	1.50
	CBT30-C25-80	P2773205	25	62.5	80	70	2.00
40	CBT40-C20-80	P2773201	20	54	80	70	2.00
	CBT40-C20-105	P2773206	20	54	105	70	2.10
	CBT40-C25-105	P2773207	25	62.5	105	80	2.50
	CBT40-C32-90	P2773202	32	72	90	100	3.00
	CBT40-C32-105	P2773203	32	72	105	100	3.10
	CBT40-C32-135	P2773208	32	72	135	100	3.30
50	CBT50-C20-105	P2773209	20	54	105	70	4.50
	CBT50-C20-135	P2773210	20	54	135	70	4.90
	CBT50-C20-165	P2773211	20	54	165	70	5.40
	CBT50-C25-105	P2773212	25	62.5	105	80	5.20
	CBT50-C25-135	P2773213	25	62.5	135	80	5.80
	CBT50-C25-165	P2773214	25	62.5	165	80	6.20
	CBT50-C32-105	P2773215	32	72	105	100	6.00
	CBT50-C32-115	P2773216	32	72	115	100	6.20
	CBT50-C32-135	P2773217	32	72	135	100	6.70
	CBT50-C32-165	P2773218	32	72	165	100	7.40
	CBT50-C42-115	P2773219	42	92	115	110	6.70
CBT50-C42-135	P2773220	42	92	135	110	7.60	
CBT50-C42-165	P2773221	42	92	165	110	8.30	

TOOLING SYSTEM

HYDRAULIC CHUCK

SHRINK FIT HOLDER

ER COLLET CHUCK

END MILL HOLDER & SIDE LOCK ARBOR

SHELL MILL ARBOR

POWER MILLING CHUCK

MORSE TAPER ARBOR

SK SLIM CHUCK

SYNCHRO TAPPING CHUCK

ONE STEP TAPPING CHUCK

TAPPING ER CHUCK

TAPPING CHUCK

FACE MILL ARBOR

COPY MILL ARBOR & INDEXABLE DRILL HOLDER

NC DRILL CHUCK & OTHER TOOL HOLDERS

BORING SYSTEM

ACCESSORY & OTHERS

HIGH-SPEED POWER MILLING CHUCK

JIS B6339/MAS 403-BT

HOCHGESCHWINDIGKEITS FRÄSERFUTTER
 MANDRIN PORTE FRAISE À GRANDE VITESSE
 MANDRINI PORTA FRESA PER ALTA VELOCITÀ
 PORTAHERRAMIENTAS PARA FRESADO DE ALTA VELOCIDAD

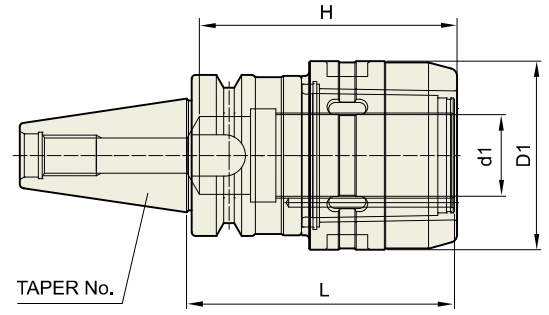

							Unit : mm
TAPER No.	MODEL No.	EDP No.	d1	D1	L	H	WEIGHT (kg)
30	BT30-C20-75HS	P2546101	20	54	75	70	1.50
	BT30-C25-80HS	P2546102	25	62.5	80	70	2.00
40	BT40-C20-80HS	P2546103	20	54	80	70	2.00
	BT40-C20-105HS	P2546104	20	54	105	70	2.10
	BT40-C25-105HS	P2546105	25	62.5	105	80	2.50
	BT40-C32-90HS	P2546106	32	74	90	100	3.00
	BT40-C32-105HS	P2546107	32	74	105	100	3.10
	BT40-C32-135HS	P2546108	32	74	135	100	3.30
50	BT50-C20-105HS	P2546109	20	54	105	70	4.50
	BT50-C20-135HS	P2546110	20	54	135	70	4.90
	BT50-C20-165HS	P2546111	20	54	165	70	5.40
	BT50-C25-105HS	P2546112	25	62.5	105	80	5.20
	BT50-C25-135HS	P2546113	25	62.5	135	80	5.80
	BT50-C25-165HS	P2546114	25	62.5	165	80	6.20
	BT50-C32-105HS	P2546115	32	74	105	100	6.00
	BT50-C32-135HS	P2546116	32	74	135	100	6.70
	BT50-C32-165HS	P2546117	32	74	165	100	7.40
	BT50-C42-115HS	P2546118	42	92	115	110	6.70
BT50-C42-135HS	P2546119	42	92	135	110	7.60	
BT50-C42-165HS	P2546120	42	92	165	110	8.30	

▶ CAT(ANSI B5.50) taper and Inch type products are available.

POWER MILLING CHUCK

JIS B6339/MAS 403-BT

FRÄSERSPANNFUTTER
 MANDRIN PORTE FRAISE
 MANDRINI PORTA FRESA
 PORTAHERRAMIENTAS PARA FRESADO

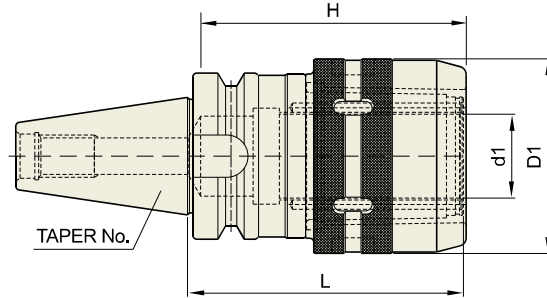

							Unit : mm
TAPER No.	MODEL No.	EDP No.	d1	D1	L	H	WEIGHT (kg)
30	BT30-C20-75	P2546001	20	54	75	70	1.50
	BT30-C25-80	P2546002	25	62.5	80	70	2.00
40	BT40-C20-80	P2546003	20	54	80	70	2.00
	BT40-C20-105	P2546004	20	54	105	70	2.10
	BT40-C25-105	P2546005	25	62.5	105	80	2.50
	BT40-C32-90	P2546006	32	72	90	100	3.00
	BT40-C32-105	P2546007	32	72	105	100	3.10
	BT40-C32-135	P2546008	32	72	135	100	3.30
	50	BT50-C20-105	P2546009	20	54	105	70
BT50-C20-135		P2546010	20	54	135	70	4.90
BT50-C20-165		P2546011	20	54	165	70	5.40
BT50-C25-105		P2546012	25	62.5	105	80	5.20
BT50-C25-135		P2546013	25	62.5	135	80	5.80
BT50-C25-165		P2546014	25	62.5	165	80	6.20
BT50-C32-105		P2546015	32	72	105	100	6.00
BT50-C32-115		P2546016	32	72	115	100	6.20
BT50-C32-135		P2546017	32	72	135	100	6.70
BT50-C32-165		P2546018	32	72	165	100	7.40
BT50-C42-115		P2546019	42	92	115	110	6.70
BT50-C42-135		P2546020	42	92	135	110	7.60
BT50-C42-165	P2546121	42	92	165	110	8.30	

▶ CAT(ANSI B5.50) taper and Inch type products are available.

HYDRAULIC CHUCK

SHRINK FIT HOLDER

ER COLLET CHUCK

END MILL HOLDER & SIDE LOCK ARBOR

SHELL MILL ARBOR

POWER MILLING CHUCK

MORSE TAPER ARBOR

SK SLIM CHUCK

SYNCHRO TAPPING CHUCK

ONE STEP TAPPING CHUCK

TAPPING ER CHUCK

TAPPING CHUCK

FACE MILL ARBOR

COPY MILL ARBOR & INDEXABLE DRILL HOLDER

NC DRILL CHUCK & OTHER TOOL HOLDERS

BORING SYSTEM

ACCESSORY & OTHERS

POWER MILLING CHUCK

DIN 228-MTA

FRÄSERSPANNFUTTER
MANDRIN PORTE FRAISE
MANDRINI PORTA FRESA
PORTAHERRAMIENTAS PARA FRESADO

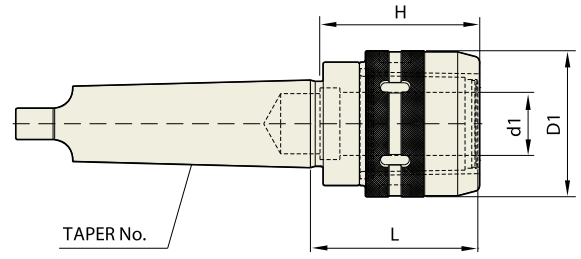

Unit : mm

TAPER No.	MODEL No.	EDP No.	d1	D1	L	H	WEIGHT (kg)
4	MTA4-C32	P2546122	32	72	98	85	2.57
5	MTA5-C32	P2546123	32	72	85	100	3.06
	MTA5-C42	P2546124	42	92	114	100	3.45
6	MTA6-C42	P2546125	42	92	99	110	4.14

► In case of MT6, it is required to inform machine model number and company name for selection of cutter groove.

DIN 228-MTB

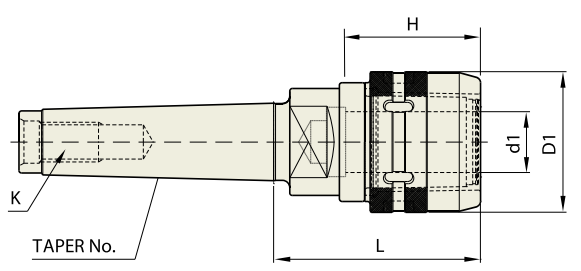

Collet, spanner, refer to page 176

Unit : mm

TAPER No.	MODEL No.	EDP No.	d1	D1	L	H	K	WEIGHT (kg)
3	MTB3-C20	P2546126	20	54	74	65	M12	2.10
4	MTB4-C32	P2546127	32	72	98	80	M16	2.57
5	MTB5-C32	P2546128	32	72	85	100	M20	3.06
	MTB5-C42	P2546129	42	92	114	100	M20	3.45

POWER MILLING CHUCK

BRIDGEPORT-R8

FRÄSERSPANNFUTTER
 MANDRIN PORTE FRAISE
 MANDRINI PORTA FRESA
 PORTAHERRAMIENTAS PARA FRESADO

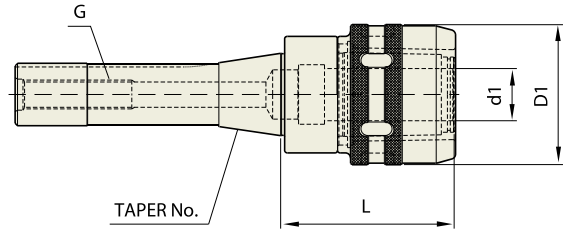

 Collet, spanner
 Refer to page 176

TAPER No.	MODEL No.	EDP No.	d1	D1	L	G	WEIGHT (kg)
R8	R8-C20	P2546130	20	54	69	U7/16-20	1.40

Unit : mm

HYDRAULIC CHUCK

SHRINK FIT HOLDER

ER COLLET CHUCK

END MILL HOLDER & SIDE LOCK ARBOR

SHELL MILL ARBOR

POWER MILLING CHUCK

MORSE TAPER ARBOR

SK SLIM CHUCK

SYNCHRO TAPPING CHUCK

ONE STEP TAPPING CHUCK

TAPPING ER CHUCK

TAPPING CHUCK

FACE MILL ARBOR

COPY MILL ARBOR & INDEXABLE DRILL HOLDER

NC DRILL CHUCK & OTHER TOOL HOLDERS

BORING SYSTEM

ACCESSORY & OTHERS



MILLING CHUCK STANDARD SET

GEGENSTÜCK FÜR FRÄSERSPANNFUTTER

ETUI AVEC PORTE-FRAISE ET CLEF

CASSETTA COMPLETA DI MANDRINO, CHIAVE E PINZE

ESTUCHE CON PORTAPINZAS, PINZAS Y LLAVE



TAPER	STANDARD SET MODEL No.	EDP No.	MILLING CHUCK	END MILL COLLET	SPANNER
SK	SSK40-C20	P2526031	SK40-C20-105	K20-6, 8, 10, 12, 16 (5pcs)	C20 SP
	SSK40-C32	P2773301	SK40-C32-105	K32-6, 8, 10, 12, 16, 20, 25 (7pcs)	C32 SP
	SSK50-C32	P2773302	SK50-C32-105	K32-6, 8, 10, 12, 16, 20, 25 (7pcs)	C32 SP
	SSK50-C42	P2773303	SK50-C42-115	K42-6, 8, 10, 12, 16, 20, 25, 32 (8pcs)	C42 SP
BT	SBT40-C20	P2546021	BT40-C20-105	K20-6, 8, 10, 12, 16 (5pcs)	C20 SP
	SBT40-C32	P2546022	BT40-C32-105	K32-6, 8, 10, 12, 16, 20, 25 (7pcs)	C32 SP
	SBT50-C32	P2546023	BT50-C32-105	K32-6, 8, 10, 12, 16, 20, 25 (7pcs)	C32 SP
	SBT50-C42	P2546024	BT50-C42-115	K42-6, 8, 10, 12, 16, 20, 25, 32 (8pcs)	C42 SP
ISO	SISO40-C20	P2516021	ISO40-C20-78	K20-6, 8, 10, 12, 16 (5pcs)	C20 SP
	SISO40-C32	P2516022	ISO40-C32-78	K32-6, 8, 10, 12, 16, 20, 25 (7pcs)	C32 SP
	SISO50-C32	P2516023	ISO50-C32-85	K32-6, 8, 10, 12, 16, 20, 25 (7pcs)	C32 SP
	SISO50-C42	P2516024	ISO50-C42-102	K42-6, 8, 10, 12, 16, 20, 25, 32 (8pcs)	C42 SP
NT	SNT40-C32	P2773304	NT40-C32	K32-6, 8, 10, 12, 16, 20, 25 (7pcs)	C32 SP
	SNT50-C32	P2773305	NT50-C32	K32-6, 8, 10, 12, 16, 20, 25 (7pcs)	C32 SP
	SNT50-C42	P2773306	NT50-C42	K42-6, 8, 10, 12, 16, 20, 25, 32 (8pcs)	C42 SP



QUICK CHANGE MILLING CHUCK SET

SCHNELLWECHSEL GEGENSTÜCK FÜR FRÄSERSPANNFUTTER
 CHANGEMENT RAPIDE ETUI AVEC PORTE-FRAISE ET CLEF
 CAMBIO RAPIDO CASSETTA COMPLETA DI MANDRINO, CHIAVE E PINZE
 CAMBIO RAPIDO ESTUCHE CON PORTAPINZAS, PINZAS Y LLAVE



TAPER	Q.C MILLING HOLDER SET MODEL No.	EDP No.	Q.C MASTER HOLDER	Q.C MILLING CHUCK	END MILL COLLETS	Q.C FACE MILL ARBOR	Q.C DRILL CHUCK BAR	DRILL CHUCK ARBOR	Q.C TAPER SLEEVE	SPANNER
NT40	SMH40-T35-32A	P2773307	MH40-T35	QT35-32	K32-(6-25)(7pcs)	QT35-4R	-	K32-J6	-	MH40 SP
	SMH40-T35-32B	P2773308	MH40-T35	QT35-32	K32-(6-25)(7pcs)	QT35-4R	QT35-J6	-	QT35-MT2, 3, 4	MH40 SP
NT50	SMH50-T45-32A	P2773309	MH50-T45	QT45-32	K32-(6-25)(7pcs)	QT45-5R	-	K32-J6	-	MH50 SP
	SMH50-T45-32B	P2773310	MH50-T45	QT45-32	K32-(6-25)(7pcs)	QT45-5R	QT45-J6	-	QT45-MT2, 3, 4	MH50 SP
	SMH50-T45-42A	P2773311	MH50-T45	QT45-42	K42-(6-32)(8pcs)	QT45-5R	-	K42-J6	-	MH50 SP
	SMH50-T45-42B	P2773312	MH50-T45	QT45-42	K42-(6-32)(8pcs)	QT45-5R	QT45-J6	-	QT45-MT2, 3, 4	MH50 SP

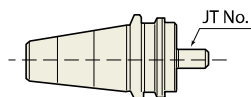
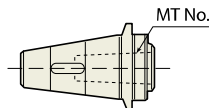
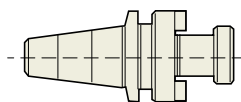
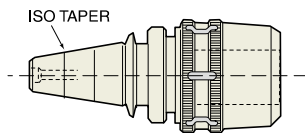
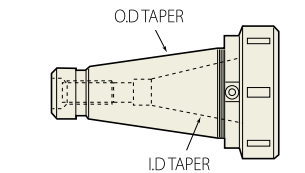

◆ Q.C MASTER HOLDER

MODEL No.	EDP No.	O.D TAPER	I.D TAPER	DRAW THREADS
MH40-T35	P2773313	NT40	NT35	U5/8-11(M16-2)
MH50-T45	P2773314	NT50	NT45	U1-8 (M24-3)

◆ Q.C MILLING CHUCK

Q.C MASTER HOLDER	MODEL No.	EDP No.
MH40	QT35-C32	P2773315
MH50	QT45-C32	P2773316
MH50	QT45-C42	P2773317

◆ Q.C FACE MILL ARBOR

Q.C MASTER HOLDER	MODEL No.	EDP No.
MH40	QT35-3R	P2773318
	QT35-4R	P2773319
	QT35-5R	P2773320
MH50	QT45-3R	P2773321
	QT45-4R	P2773322
	QT45-5R	P2773323
	QT45-6R	P2773324

◆ Q.C TAPER SLEEVE

Q.C MASTER HOLDER	MODEL No.	EDP No.
MH40	QT35-MT1	P2773325
	QT35-MT2	P2773326
	QT35-MT3	P2773327
MH50	QT45-MT1	P2773328
	QT45-MT2	P2773329
	QT45-MT3	P2773330
	QT45-MT4	P2773331

◆ Q.C DRILL CHUCK ARBOR

Q.C MASTER HOLDER	MODEL No.	EDP No.	DRILL (Ø)
MH40	QT35-J6	P2773332	1-13mm
MH50	QT45-J6	P2773333	1-13mm



COLLET & SPANNER



■ END MILL COLLET (K TYPE)

MODEL No.	EDP No.
K20-6	P2506401
K20-8	P2506402
K20-10	P2506403
K20-12	P2506404
K20-16	P2506405
K25-6	P2506601
K25-8	P2506602
K25-10	P2506603
K25-12	P2506604
K25-16	P2506605
K25-20	P2506606
K32-6	P2506411
K32-8	P2506412
K32-10	P2506413
K32-12	P2506414
K32-16	P2506415
K32-20	P2506416
K32-25	P2506417
K42-6	P2506511
K42-8	P2506512
K42-10	P2506513
K42-12	P2506514
K42-16	P2506515
K42-20	P2506516
K42-25	P2506517
K42-32	P2506518

■ END MILL COLLET (CK TYPE)

MODEL No.	EDP No.
CK20-6	P2506731
CK20-8	P2506732
CK20-10	P2506733
CK20-12	P2506734
CK20-16	P2506735
CK25-6	P2506736
CK25-8	P2506737
CK25-10	P2506738
CK25-12	P2506739
CK25-16	P2506740
CK25-20	P2506741
CK32-6	P2506742
CK32-8	P2506743
CK32-10	P2506744
CK32-12	P2506745
CK32-16	P2506746
CK32-20	P2506747
CK32-25	P2506748
CK42-6	P2506749
CK42-8	P2506750
CK42-10	P2506751
CK42-12	P2506752
CK42-16	P2506753
CK42-20	P2506754
CK42-25	P2506755
CK42-32	P2506756

■ MT COLLET

MODEL No.	EDP No.
K20-MT1	P2506519
K20-MT2	P2506520
K25-MT1	P2506521
K25-MT2	P2506522
K25-MT3	P2506534
K32-MT1	P2506523
K32-MT2	P2506524
K32-MT3	P2506525
K42-MT1	P2506526
K42-MT2	P2506527
K42-MT3	P2506528
K42-MT4	P2506529



■ DRILL CHUCK ARBOR

MODEL No.	EDP No.
K20-JTA6	P2506530
K25-JTA6	P2506531
K32-JTA6	P2506532
K42-JTA6	P2506533

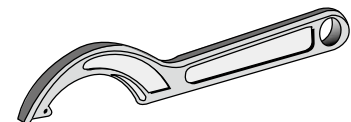

■ SPANNER

MODEL No.	EDP No.
C20 SP	P2773401
C25 SP	P2773402
C32 SP	P2600033
C42 SP	P2773403



Global Cutting Tool Leader **YG-1**

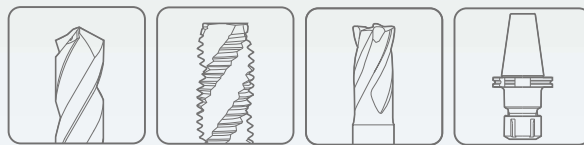



HEAD OFFICE

13-40, Songdogwahak-ro 16beon-gil, Yeonsu-gu, Incheon 21984, South Korea

Notice YG-1 Global head office is relocating from December 2020 to a new address as above;

Phone: +82-32-526-0909

Https://www.yg1.kr **E-mail:** yg1@yg1.kr

Note The information is provided for reference only. Tool specifications are subject to change without prior notice. Although we endeavor to supply accurate and timely information, there can be no guarantee to cover every particular application. YG-1 or publishers are not liable for any damage for use of the information.



Search 'YG-1' on social media outlets

YG1YE211020002-1