

YG-1 TOOLING SYSTEM

END MILL HOLDER & SIDE LOCK ARBOR

- FRÄSERFUTTER UND FLÄCHENSPANNFUTTER
- MANDRIN PORTE FRAISE À QUEUE CYLINDRIQUE, À MÉPLAT
- MANDRINI PORTA FRESA TIPO WELDON
- PORTAFRESAS Y EJES DE SUJECCION LATERAL



END MILL HOLDER

DIN 69871-SK

DIN 69893/ISO 12164-1-HSK

JIS B6339/MAS 403-BT

SHORT TYPE (SK&BT)

GOST 25827-93

SIDE LOCK ARBOR

CBT (BT DUAL CONTACT)

JIS B6339/MAS 403-BT

PART



END MILL HOLDER

DIN 69871-SK

FRÄSERFUTTER UND FLÄCHENSANNFUTTER
 MANDRIN PORTE FRAISE À QUEUE CYLINDRIQUE, À MÉPLAT
 MANDRINI PORTA FRESA TIPO WELDON
 PORTAFRESAS Y EJES DE SUJECCION LATERAL

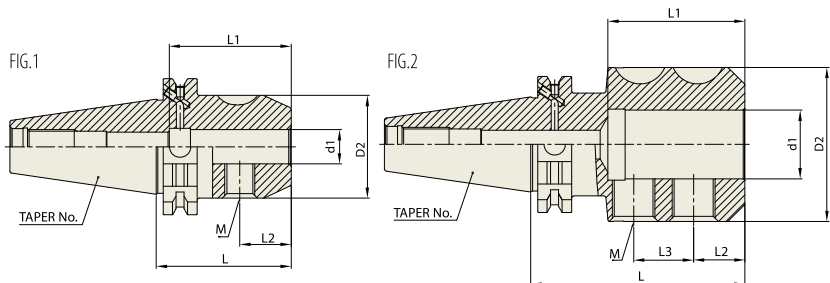

Unit : mm

TAPER No.	MODEL No.	EDP No.	d1	D2	L	L1	L2	L3	M	FIG.	WEIGHT (kg)
30	SK30-EMH6-50	P2779025A	6	25	50	35	18	-	M6	1	0.73
	SK30-EMH8-50	P2779026A	8	28	50	35	18	-	M8	1	0.83
	SK30-EMH10-50	P2779027A	10	35	50	42	20	-	M10	1	0.90
	SK30-EMH12-50	P2779028A	12	42	50	47	22.5	-	M12	1	0.90
	SK30-EMH16-63	P2779029A	16	48	63	50	24	-	M14	1	1.10
40	SK40AD/B-EMH6-50	P2779030	6	25	50	35	18	-	M6	1	0.86
	SK40AD/B-EMH8-50	P2779031	8	28	50	35	18	-	M8	1	0.89
	SK40AD/B-EMH10-50	P2779032	10	35	50	39	20	-	M10	1	0.95
	SK40AD/B-EMH12-50	P2779033	12	42	50	46	22.5	-	M12	1	1.03
	SK40AD/B-EMH16-63	P2779034	16	48	63	57	24	-	M14	1	1.26
	SK40AD/B-EMH20-63	P2779035	20	52	63	54	25	-	M16	1	1.28
	SK40AD/B-EMH25-100	P2779036	25	65	100	60	24	25	M18	2	2.28
	SK40AD/B-EMH32-100	P2779037	32	72	100	64	24	28	M20	2	2.50
50	SK50AD/B-EMH6-63	P2779038	6	25	63	35	18	-	M6	1	2.70
	SK50AD/B-EMH8-63	P2779039	8	28	63	35	18	-	M8	1	2.70
	SK50AD/B-EMH10-63	P2779040	10	35	63	39	20	-	M10	1	2.90
	SK50AD/B-EMH12-63	P2779041	12	42	63	46	22.5	-	M12	1	2.90
	SK50AD/B-EMH16-63	P2779042	16	48	63	49	24	-	M14	1	3.00
	SK50AD/B-EMH20-63	P2779043	20	52	63	52	25	-	M16	1	3.05
	SK50AD/B-EMH25-80	P2779044	25	65	80	60	24	25	M18	2	3.73
	SK50AD/B-EMH32-100	P2779045	32	72	100	64	24	28	M20	2	4.53
	SK50AD/B-EMH40-100	P2779046	40	80	100	74	30	32	M20	2	4.77
SK50AD/B-EMH50-125	P2779047	50	100	125	84	35	35	M24	2	7.03	

- ▶ CAT(ANSI B5.50) taper and Inch type products are available.
- ▶ Standard End Mill Holder is for a cutting tool with Weldon shank and End Mill Holder for a cutting tool with Whistle notch is available upon request.
- ▶ Combi-style holder with ball jointed clamping screw which can be used with cutting tools with Weldon and Whistle notch shank is available.



END MILL HOLDER & SIDE LOCK ARBOR

EMH

END MILL HOLDER (COOLANT CHANNEL)

DIN 69871-SK

FRÄSERFUTTER UND FLÄCHENSPIANNFUTTER
MANDRIN PORTE FRAISE À QUEUE CYLINDRIQUE, À MÉPLAT
MANDRINI PORTA FRESA TIPO WELDON
PORTAFRESAS Y EJES DE SUJECCION LATERAL

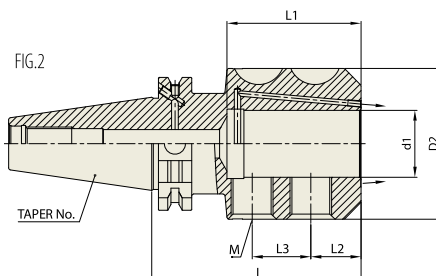
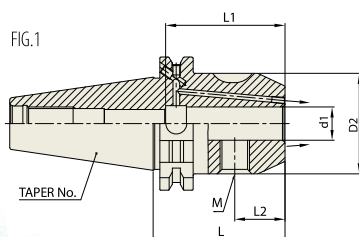
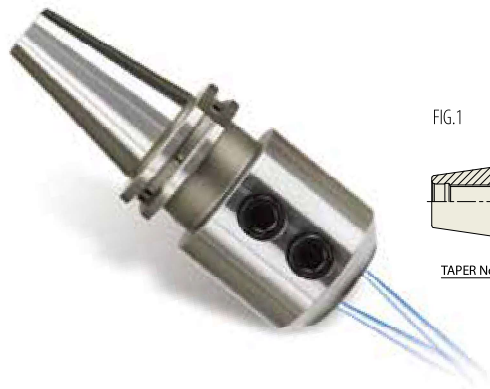

Unit : mm

TAPER No.	MODEL No.	EDP No.	d1	D2	L	L1	L2	L3	M	FIG.	WEIGHT (kg)
40	SK40AD/B-EMH6C-50	P2779048	6	25	50	35	18	-	M6	1	0.86
	SK40AD/B-EMH8C-50	P2779049	8	28	50	35	18	-	M8	1	0.89
	SK40AD/B-EMH10C-50	P2779050	10	35	50	39	20	-	M10	1	0.95
	SK40AD/B-EMH12C-50	P2779051	12	42	50	46	22.5	-	M12	1	1.03
	SK40AD/B-EMH14C-50	P2779052	14	44	50	48	22.5	-	M12	1	1.26
	SK40AD/B-EMH16C-63	P2779053	16	48	63	57	24	-	M14	1	1.28
	SK40AD/B-EMH18C-63	P2779054	18	50	63	54	24	-	M14	1	1.35
	SK40AD/B-EMH20C-63	P2779055	20	52	63	54	25	-	M16	1	1.28
	SK40AD/B-EMH25C-100	P2779056	25	65	100	60	24	25	M18	2	2.28
SK40AD/B-EMH32C-100	P2779057	32	72	100	64	24	28	M20	2	2.50	
50	SK50AD/B-EMH6C-63	P2779058	6	25	63	35	18	-	M6	1	2.70
	SK50AD/B-EMH8C-63	P2779059	8	28	63	35	18	-	M8	1	2.70
	SK50AD/B-EMH10C-63	P2779060	10	35	63	39	20	-	M10	1	2.90
	SK50AD/B-EMH12C-63	P2779061	12	42	63	46	22.5	-	M12	1	2.90
	SK50AD/B-EMH14C-63	P2779062	14	44	63	45	22.5	-	M12	1	2.90
	SK50AD/B-EMH16C-63	P2779063	16	48	63	49	24	-	M14	1	3.00
	SK50AD/B-EMH18C-63	P2779064	18	50	63	46	24	-	M14	1	3.00
	SK50AD/B-EMH20C-63	P2779065	20	52	63	52	25	-	M16	1	3.05
	SK50AD/B-EMH25C-80	P2779066	25	65	80	60	24	25	M18	2	3.73
	SK50AD/B-EMH32C-100	P2779067	32	72	100	64	24	28	M20	2	4.53
	SK50AD/B-EMH40C-120	P2779068	40	80	120	74	30	32	M20	2	4.77
	SK50AD/B-EMH50C-125	P2779069	50	100	125	84	35	35	M24	2	7.03

- ▶ CAT(ANSI B5.50) taper and Inch type products are available.
- ▶ Standard End Mill Holder is for a cutting tool with Weldon shank and End Mill Holder for a cutting tool with Whistle notch is available upon request.
- ▶ Combi-style holder with ball jointed clamping screw which can be used with cutting tools with Weldon and Whistle notch shank is available.



END MILL HOLDER

DIN 69871-SK

FRÄSERFUTTER UND FLÄCHENSANNFUTTER
 MANDRIN PORTE FRAISE À QUEUE CYLINDRIQUE, À MÉPLAT
 MANDRINI PORTA FRESA TIPO WELDON
 PORTAFRESAS Y EJES DE SUJECCION LATERAL

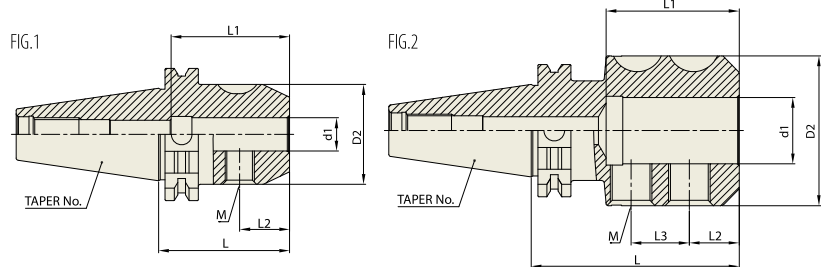

Unit : mm

TAPER No.	MODEL No.	EDP No.	d1	D2	L	L1	L2	L3	M	FIG.	WEIGHT (kg)
30	SK30-EMH6-50	P2521004	6	25	50	35	18	-	M6	1	0.73
	SK30-EMH8-50	P2521005	8	28	50	35	18	-	M8	1	0.83
	SK30-EMH10-50	P2521006	10	35	50	42	20	-	M10	1	0.90
	SK30-EMH12-50	P2521007	12	42	50	47	22.5	-	M12	1	0.90
40	SK30-EMH16-63	P2521008	16	48	63	50	24	-	M14	1	1.10
	SK40-EMH6-50	P2521009	6	25	50	35	18	-	M6	1	0.86
	SK40-EMH8-50	P2521010	8	28	50	35	18	-	M8	1	0.89
	SK40-EMH10-50	P2521011	10	35	50	39	20	-	M10	1	0.95
	SK40-EMH12-50	P2521012	12	42	50	46	22.5	-	M12	1	1.03
	SK40-EMH16-63	P2521013	16	48	63	57	24	-	M14	1	1.26
	SK40-EMH20-63	P2521014	20	52	63	54	25	-	M16	1	1.28
	SK40-EMH25-100	P2521015	25	65	100	60	24	25	M18	2	2.28
50	SK40-EMH32-100	P2521016	32	72	100	64	24	28	M20	2	2.50
	SK50-EMH6-63	P2521017	6	25	63	35	18	-	M6	1	2.70
	SK50-EMH8-63	P2521018	8	28	63	35	18	-	M8	1	2.70
	SK50-EMH10-63	P2521019	10	35	63	39	20	-	M10	1	2.90
	SK50-EMH12-63	P2521020	12	42	63	46	22.5	-	M12	1	2.90
	SK50-EMH16-63	P2521021	16	48	63	49	24	-	M14	1	3.00
	SK50-EMH20-63	P2521022	20	52	63	52	25	-	M16	1	3.05
	SK50-EMH25-80	P2521023	25	65	80	60	24	25	M18	2	3.73
	SK50-EMH32-100	P2521024	32	72	100	64	24	28	M20	2	4.53
	SK50-EMH40-100	P2521025	40	80	100	74	30	32	M20	2	4.77
	SK50-EMH50-125	P2521026	50	100	125	84	35	35	M24	2	7.03

- ▶ CAT(ANSI B5.50) taper and Inch type products are available.
- ▶ Standard End Mill Holder is for a cutting tool with Weldon shank and End Mill Holder for a cutting tool with Whistle notch is available upon request.
- ▶ Combi-style holder with ball jointed clamping screw which can be used with cutting tools with Weldon and Whistle notch shank is available.



END MILL HOLDER & SIDE LOCK ARBOR

EMH

END MILL HOLDER

DIN 69871-SK

FRÄSERFUTTER UND FLÄCHENSPIANNFUTTER
MANDRIN PORTE FRAISE À QUEUE CYLINDRIQUE, À MÉPLAT
MANDRINI PORTA FRESA TIPO WELDON
PORTAFRESAS Y EJES DE SUJECCION LATERAL

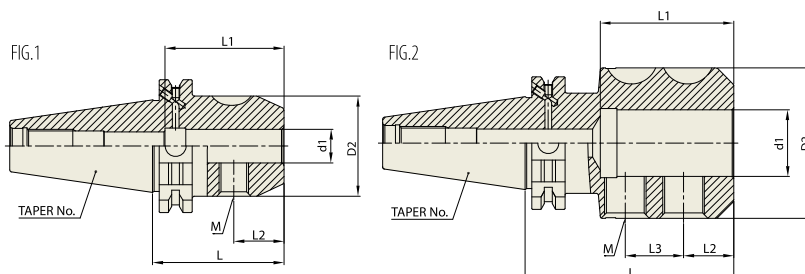

Unit : mm

TAPER No.	MODEL No.	EDP No.	d1	D2	L	L1	L2	L3	M	FIG.	WEIGHT (kg)
40	SK40AD/B-EMH6-50	P2531009	6	25	50	35	18	-	M6	1	0.86
	SK40AD/B-EMH8-50	P2531010	8	28	50	35	18	-	M8	1	0.89
	SK40AD/B-EMH10-50	P2531011	10	35	50	39	20	-	M10	1	0.95
	SK40AD/B-EMH12-50	P2531012	12	42	50	46	22.5	-	M12	1	1.03
	SK40AD/B-EMH16-63	P2531013	16	48	63	57	24	-	M14	1	1.28
	SK40AD/B-EMH20-63	P2531014	20	52	63	54	25	-	M16	1	1.28
	SK40AD/B-EMH25-100	P2531015	25	65	100	60	24	25	M18	2	2.28
	SK40AD/B-EMH32-100	P2531016	32	72	100	64	24	28	M20	2	2.50
50	SK50AD/B-EMH6-63	P2531017	6	25	63	35	18	-	M6	1	2.70
	SK50AD/B-EMH8-63	P2531018	8	28	63	35	18	-	M8	1	2.70
	SK50AD/B-EMH10-63	P2531019	10	35	63	39	20	-	M10	1	2.90
	SK50AD/B-EMH12-63	P2531020	12	42	63	46	22.5	-	M12	1	2.90
	SK50AD/B-EMH16-63	P2531021	16	48	63	49	24	-	M14	1	3.00
	SK50AD/B-EMH20-63	P2531022	20	52	63	52	25	-	M16	1	3.05
	SK50AD/B-EMH25-80	P2531023	25	65	80	60	24	25	M18	2	3.73
	SK50AD/B-EMH32-100	P2531024	32	72	100	64	24	28	M20	2	4.53
	SK50AD/B-EMH40-100	P2531025	40	80	100	74	30	32	M20	2	4.77
	SK50AD/B-EMH50-125	P2531026	50	100	125	84	35	35	M24	2	7.03

- ▶ CAT(ANSI B5.50) taper and Inch type products are available.
- ▶ Standard End Mill Holder is for a cutting tool with Weldon shank and End Mill Holder for a cutting tool with Whistle notch is available upon request.
- ▶ Combi-style holder with ball jointed clamping screw which can be used with cutting tools with Weldon and Whistle notch shank is available.

TOOLING SYSTEM

HYDRAULIC CHUCK

SHRINK FIT HOLDER

ER COLLET CHUCK

END MILL HOLDER & SIDE LOCK ARBOR

SHELL MILL ARBOR

POWER MILLING CHUCK

MORSE TAPER ARBOR

SK SLIM CHUCK

SYNCHRO TAPPING CHUCK

ONE STEP TAPPING CHUCK

TAPPING ER CHUCK

TAPPING CHUCK

FACE MILL ARBOR

COPY MILL ARBOR & INDEXABLE DRILL HOLDER

NC DRILL CHUCK & OTHER TOOL HOLDERS

BORING SYSTEM

ACCESSORY & OTHERS

YG END MILL HOLDER & SIDE LOCK ARBOR

EMH

END MILL HOLDER (COOLANT CHANNEL)

DIN 69871-SK

FRÄSERFUTTER UND FLÄCHENSPIANNFUTTER
 MANDRIN PORTE FRAISE À QUEUE CYLINDRIQUE, À MÉPLAT
 MANDRINI PORTA FRESA TIPO WELDON
 PORTAFRESAS Y EJES DE SUJECCION LATERAL

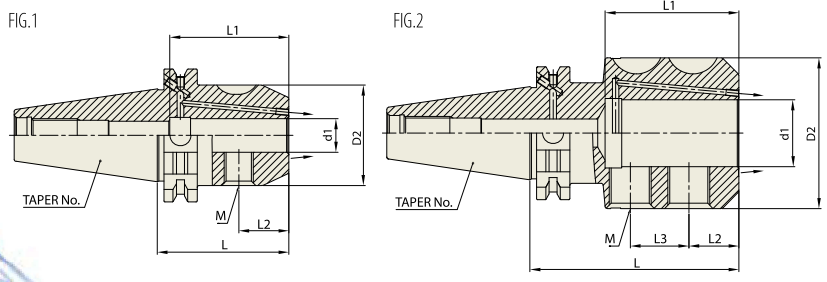
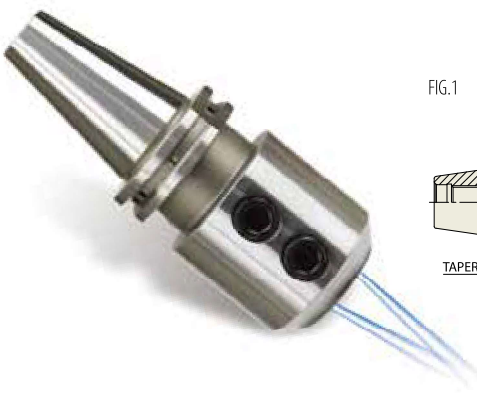

DIN 69871-SK
AT3
6.3G
15,000 RPM
AD/B+C

Unit : mm

TAPER No.	MODEL No.	EDP No.	d1	D2	L	L1	L2	L3	M	FIG.	WEIGHT (kg)
40	SK40AD/B-EMH6C-50	P2779001	6	25	50	35	18	-	M6	1	0.86
	SK40AD/B-EMH8C-50	P2779002	8	28	50	35	18	-	M8	1	0.89
	SK40AD/B-EMH10C-50	P2779003	10	35	50	39	20	-	M10	1	0.95
	SK40AD/B-EMH12C-50	P2779004	12	42	50	46	22.5	-	M12	1	1.03
	SK40AD/B-EMH14C-50	P2779005	14	44	50	48	22.5	-	M12	1	1.26
	SK40AD/B-EMH16C-63	P2779006	16	48	63	57	24	-	M14	1	1.28
	SK40AD/B-EMH18C-63	P2779007	18	50	63	54	24	-	M14	1	1.35
	SK40AD/B-EMH20C-63	P2779008	20	52	63	54	25	-	M16	1	1.28
	SK40AD/B-EMH25C-100	P2779009	25	65	100	60	24	25	M18	2	2.28
	SK40AD/B-EMH32C-100	P2779010	32	72	100	64	24	28	M20	2	2.50
50	SK50AD/B-EMH6C-63	P2779011	6	25	63	35	18	-	M6	1	2.70
	SK50AD/B-EMH8C-63	P2779012	8	28	63	35	18	-	M8	1	2.70
	SK50AD/B-EMH10C-63	P2779013	10	35	63	39	20	-	M10	1	2.90
	SK50AD/B-EMH12C-63	P2779014	12	42	63	46	22.5	-	M12	1	2.90
	SK50AD/B-EMH14C-63	P2779015	14	44	63	45	22.5	-	M12	1	2.90
	SK50AD/B-EMH16C-63	P2779016	16	48	63	49	24	-	M14	1	3.00
	SK50AD/B-EMH18C-63	P2779017	18	50	63	46	24	-	M14	1	3.00
	SK50AD/B-EMH20C-63	P2779018	20	52	63	52	25	-	M16	1	3.05
	SK50AD/B-EMH25C-80	P2779019	25	65	80	60	24	25	M18	2	3.73
	SK50AD/B-EMH32C-100	P2779020	32	72	100	64	24	28	M20	2	4.53
	SK50AD/B-EMH40C-120	P2779021	40	80	120	74	30	32	M20	2	4.77
	SK50AD/B-EMH50C-125	P2779022	50	100	125	84	35	35	M24	2	7.03

- ▶ CAT(ANSI B5.50) taper and Inch type products are available.
- ▶ Standard End Mill Holder is for a cutting tool with Weldon shank and End Mill Holder for a cutting tool with Whistle notch is available upon request.
- ▶ Combi-style holder with ball jointed clamping screw which can be used with cutting tools with Weldon and Whistle notch shank is available.



END MILL HOLDER & SIDE LOCK ARBOR

EMH

END MILL HOLDER

FRÄSERFUTTER UND FLÄCHENSANNFUTTER
 MANDRIN PORTE FRAISE À QUEUE CYLINDRIQUE, À MÉPLAT
 MANDRINI PORTA FRESA TIPO WELDON
 PORTAFRESAS Y EJES DE SUJECCION LATERAL

**DIN 69893/
 ISO 12164-1-HSK FORM A**

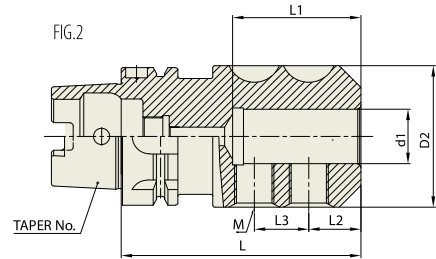
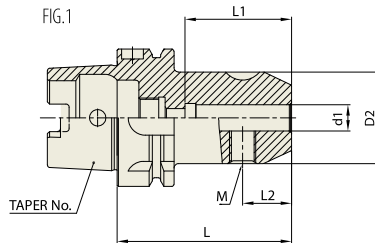

TAPER No.	MODEL No.	EDP No.	d1	D2	L	L1	L2	L3	M	FIG.	WEIGHT (kg)
40A	HSK40A-EMH6-60	P2775522	6	25	60	38	18	-	M6	1	0.30
	HSK40A-EMH8-60	P2775523	8	28	60	38	18	-	M8	1	0.30
	HSK40A-EMH10-60	P2775524	10	35	60	42	20	-	M10	1	0.30
	HSK40A-EMH12-70	P2775525	12	42	70	47	22.5	-	M12	1	0.40
	HSK40A-EMH14-70	P2775526	14	44	70	47	22.5	-	M12	1	0.40
50A	HSK40A-EMH16-80	P2775527	16	48	80	50	24	-	M14	1	0.60
	HSK50A-EMH6-65	P2775528	6	25	65	38	18	-	M6	1	0.70
	HSK50A-EMH8-65	P2775529	8	28	65	38	18	-	M8	1	0.80
	HSK50A-EMH10-65	P2775530	10	35	65	42	20	-	M10	1	0.80
	HSK50A-EMH12-80	P2775531	12	42	80	47	22.5	-	M12	1	1.20
	HSK50A-EMH14-80	P2775532	14	44	80	47	22.5	-	M12	1	1.30
	HSK50A-EMH16-80	P2775533	16	48	80	50	24	-	M14	1	1.30
63A	HSK50A-EMH18-80	P2775534	18	50	80	50	24	-	M14	1	1.40
	HSK50A-EMH20-80	P2775535	20	52	80	52	25	-	M16	1	1.50
	HSK63A-EMH6-65	P2775501	6	25	65	35	18	-	M6	1	0.80
	HSK63A-EMH8-65	P2775502	8	28	65	38	18	-	M8	1	0.80
	HSK63A-EMH10-65	P2775503	10	35	65	42	20	-	M10	1	0.90
	HSK63A-EMH12-80	P2775504	12	42	80	47	22.5	-	M12	1	1.10
	HSK63A-EMH14-80	P2775505	14	44	80	47	22.5	-	M12	1	1.20
	HSK63A-EMH16-80	P2775506	16	48	80	50	24	-	M14	1	1.30
100A	HSK63A-EMH18-80	P2775507	18	50	80	50	24	-	M14	1	1.40
	HSK63A-EMH20-80	P2775508	20	52	80	52	25	-	M16	1	1.50
	HSK63A-EMH25-110	P2775509	25	65	110	60	24	25	M18	2	2.30
	HSK63A-EMH32-110	P2775510	32	72	110	64	24	28	M20	2	2.60
	HSK100A-EMH6-80	P2775511	6	25	80	35	18	-	M6	1	0.80
	HSK100A-EMH8-80	P2775512	8	28	80	35	18	-	M8	1	0.80
	HSK100A-EMH10-80	P2775513	10	35	80	39	20	-	M10	1	0.90
100A	HSK100A-EMH12-80	P2775514	12	42	80	47	22.5	-	M12	1	1.10
	HSK100A-EMH14-80	P2775515	14	44	80	47	22.5	-	M12	1	1.20
	HSK100A-EMH16-100	P2775516	16	48	100	50	24	-	M14	1	1.30
	HSK100A-EMH18-100	P2775517	18	50	100	50	24	-	M14	1	1.40
	HSK100A-EMH20-100	P2775518	20	52	100	52	25	-	M16	1	1.50
	HSK100A-EMH25-100	P2775519	25	65	100	60	24	25	M18	2	2.30
	HSK100A-EMH32-100	P2775520	32	72	100	64	24	28	M20	2	2.60
	HSK100A-EMH40-120	P2775521	40	80	120	74	30	32	M20	2	2.60

► Standard End Mill Holder is for a cutting tool with Weldon shank and End Mill Holder for a cutting tool with Whistle notch is available upon request.
 ► Combi-style holder with ball jointed clamping screw which can be used with cutting tools with Weldon and Whistle notch shank is available.



END MILL HOLDER & SIDE LOCK ARBOR

EMH

END MILL HOLDER (COOLANT CHANNEL)

DIN 69893/
ISO 12164-1-HSK FORM A

FRÄSERFUTTER UND FLÄCHENSANNFUTTER
MANDRIN PORTE FRAISE À QUEUE CYLINDRIQUE, À MÉPLAT
MANDRINI PORTA FRESA TIPO WELDON
PORTAFRESAS Y EJES DE SUJECCION LATERAL

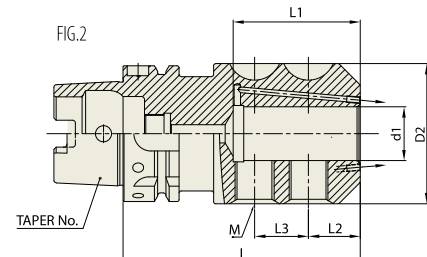
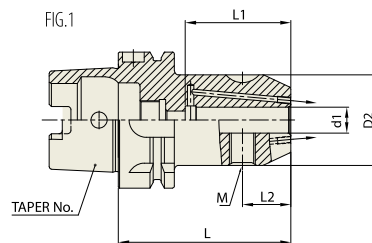

Unit : mm

TAPER No.	MODEL No.	EDP No.	d1	D2	L	L1	L2	L3	M	FIG.	WEIGHT (kg)
40A	HSK40A-EMH6C-60	P2777222	6	25	60	38	18	-	M6	1	0.30
	HSK40A-EMH8C-60	P2777223	8	28	60	38	18	-	M8	1	0.30
	HSK40A-EMH10C-60	P2777224	10	35	60	42	20	-	M10	1	0.30
	HSK40A-EMH12C-70	P2777225	12	42	70	47	22.5	-	M12	1	0.40
	HSK40A-EMH14C-70	P2777226	14	44	70	47	22.5	-	M12	1	0.40
	HSK40A-EMH16C-80	P2777227	16	48	80	50	24	-	M14	1	0.60
50A	HSK50A-EMH6C-65	P2777228	6	25	65	38	18	-	M6	1	0.70
	HSK50A-EMH8C-65	P2777229	8	28	65	38	18	-	M8	1	0.80
	HSK50A-EMH10C-65	P2777230	10	35	65	42	20	-	M10	1	0.80
	HSK50A-EMH12C-80	P2777231	12	42	80	47	22.5	-	M12	1	1.20
	HSK50A-EMH14C-80	P2777232	14	44	80	47	22.5	-	M12	1	1.30
	HSK50A-EMH16C-80	P2777233	16	48	80	50	24	-	M14	1	1.30
	HSK50A-EMH18C-80	P2777234	18	50	80	50	24	-	M14	1	1.40
	HSK50A-EMH20C-80	P2777235	20	52	80	52	25	-	M16	1	1.50
63A	HSK63A-EMH6C-65	P2777201	6	25	65	35	18	-	M6	1	0.80
	HSK63A-EMH8C-65	P2777202	8	28	65	38	18	-	M8	1	0.80
	HSK63A-EMH10C-65	P2777203	10	35	65	42	20	-	M10	1	0.90
	HSK63A-EMH12C-80	P2777204	12	42	80	47	22.5	-	M12	1	1.10
	HSK63A-EMH14C-80	P2777206	14	44	80	47	22.5	-	M12	1	1.20
	HSK63A-EMH16C-80	P2777205	16	48	80	50	24	-	M14	1	1.30
	HSK63A-EMH18C-80	P2777207	18	50	80	50	24	-	M14	1	1.40
	HSK63A-EMH20C-80	P2777208	20	52	80	52	25	-	M16	1	1.50
	HSK63A-EMH25C-110	P2777209	25	65	110	60	24	25	M18	2	2.30
	HSK63A-EMH32C-110	P2777210	32	72	110	64	24	28	M20	2	2.60
100A	HSK100A-EMH6C-80	P2777211	6	25	80	35	18	-	M6	1	0.80
	HSK100A-EMH8C-80	P2777212	8	28	80	35	18	-	M8	1	0.80
	HSK100A-EMH10C-80	P2777213	10	35	80	39	20	-	M10	1	0.90
	HSK100A-EMH12C-80	P2777214	12	42	80	47	22.5	-	M12	1	1.10
	HSK100A-EMH14C-80	P2777215	14	44	80	47	22.5	-	M12	1	1.20
	HSK100A-EMH16C-100	P2777216	16	48	100	50	24	-	M14	1	1.30
	HSK100A-EMH18C-100	P2777217	18	50	100	50	24	-	M14	1	1.40
	HSK100A-EMH20C-100	P2777218	20	52	100	52	25	-	M16	1	1.50
	HSK100A-EMH25C-100	P2777219	25	65	100	60	24	25	M18	2	2.30
	HSK100A-EMH32C-100	P2777220	32	72	100	64	24	28	M20	2	2.60
	HSK100A-EMH40C-120	P2777221	40	80	120	74	30	32	M20	2	2.60

► Standard End Mill Holder is for a cutting tool with Weldon shank and End Mill Holder for a cutting tool with Whistle notch is available upon request.
► Combi-style holder with ball jointed clamping screw which can be used with cutting tools with Weldon and Whistle notch shank is available.



END MILL HOLDER & SIDE LOCK ARBOR

EMH

END MILL HOLDER

FRÄSERFUTTER UND FLÄCHENSpanNFUTTER
MANDRIN PORTE FRAISE À QUEUE CYLINDRIQUE, À MÉPLAT
MANDRINI PORTA FRESA TIPO WELDON
PORTAFRESAS Y EJES DE SUJECCION LATERAL

DIN 69893/
ISO 12164-1-HSK FORM A

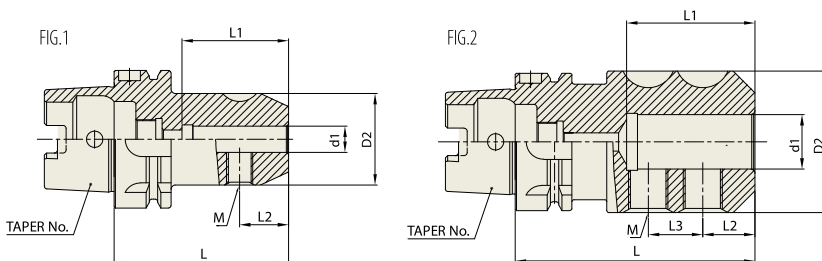

Unit : mm

TAPER No.	MODEL No.	EDP No.	d1	D2	L	L1	L2	L3	M	FIG.	WEIGHT (kg)
40A	HSK40A-EMH6-60	P2563011	6	25	60	38	18	-	M6	1	0.30
	HSK40A-EMH8-60	P2563012	8	28	60	38	18	-	M8	1	0.30
	HSK40A-EMH10-60	P2563013	10	35	60	42	20	-	M10	1	0.30
	HSK40A-EMH12-70	P2563014	12	42	70	47	22.5	-	M12	1	0.40
	HSK40A-EMH14-70	P2563015	14	44	70	47	22.5	-	M12	1	0.40
50A	HSK40A-EMH16-80	P2563016	16	48	80	50	24	-	M14	1	0.60
	HSK50A-EMH6-65	P2563017	6	25	65	38	18	-	M6	1	0.70
	HSK50A-EMH8-65	P2563018	8	28	65	38	18	-	M8	1	0.80
	HSK50A-EMH10-65	P2563019	10	35	65	42	20	-	M10	1	0.80
	HSK50A-EMH12-80	P2563020	12	42	80	47	22.5	-	M12	1	1.20
	HSK50A-EMH14-80	P2563031	14	44	80	47	22.5	-	M12	1	1.30
	HSK50A-EMH16-80	P2563032	16	48	80	50	24	-	M14	1	1.30
63A	HSK50A-EMH18-80	P2563033	18	50	80	50	24	-	M14	1	1.40
	HSK50A-EMH20-80	P2563034	20	52	80	52	25	-	M16	1	1.50
	HSK63A-EMH6-65	P2563001	6	25	65	35	18	-	M6	1	0.80
	HSK63A-EMH8-65	P2563002	8	28	65	38	18	-	M8	1	0.80
	HSK63A-EMH10-65	P2563003	10	35	65	42	20	-	M10	1	0.90
	HSK63A-EMH12-80	P2563004	12	42	80	47	22.5	-	M12	1	1.10
	HSK63A-EMH14-80	P2563005	14	44	80	47	22.5	-	M12	1	1.20
	HSK63A-EMH16-80	P2563006	16	48	80	50	24	-	M14	1	1.30
	HSK63A-EMH18-80	P2563007	18	50	80	50	24	-	M14	1	1.40
	HSK63A-EMH20-80	P2563008	20	52	80	52	25	-	M16	1	1.50
100A	HSK63A-EMH25-110	P2563009	25	65	110	60	24	25	M18	2	2.30
	HSK63A-EMH32-110	P2563010	32	72	110	64	24	28	M20	2	2.60
	HSK100A-EMH6-80	P2563041	6	25	80	35	18	-	M6	1	0.80
	HSK100A-EMH8-80	P2563042	8	28	80	35	18	-	M8	1	0.80
	HSK100A-EMH10-80	P2563043	10	35	80	39	20	-	M10	1	0.90
	HSK100A-EMH12-80	P2563044	12	42	80	47	22.5	-	M12	1	1.10
	HSK100A-EMH14-80	P2563045	14	44	80	47	22.5	-	M12	1	1.20
	HSK100A-EMH16-100	P2563046	16	48	100	50	24	-	M14	1	1.30
	HSK100A-EMH18-100	P2563047	18	50	100	50	24	-	M14	1	1.40
	HSK100A-EMH20-100	P2563048	20	52	100	52	25	-	M16	1	1.50
	HSK100A-EMH25-100	P2563049	25	65	100	60	24	25	M18	2	2.30
	HSK100A-EMH32-100	P2563050	32	72	100	64	24	28	M20	2	2.60
	HSK100A-EMH40-120	P2563051	40	80	120	74	30	32	M20	2	2.60

- ▶ Standard End Mill Holder is for a cutting tool with Weldon shank and End Mill Holder for a cutting tool with Whistle notch is available upon request.
- ▶ Combi-style holder with ball jointed clamping screw which can be used with cutting tools with Weldon and Whistle notch shank is available.



END MILL HOLDER & SIDE LOCK ARBOR

EMH

END MILL HOLDER (COOLANT CHANNEL)

DIN 69893/
ISO 12164-1-HSK FORM A

FRÄSERFUTTER UND FLÄCHENSpanNFUTTER

MANDRIN PORTE FRAISE À QUEUE CYLINDRIQUE, À MÉPLAT

MANDRINI PORTA FRESA TIPO WELDON

PORTAFRESAS Y EJES DE SUJECCION LATERAL

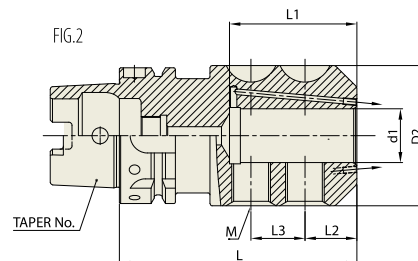
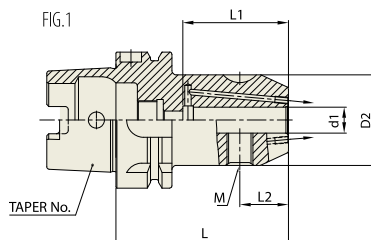

Unit : mm

TAPER No.	MODEL No.	EDP No.	d1	D2	L	L1	L2	L3	M	FIG.	WEIGHT (kg)
40A	HSK40A-EMH6C-60	P2563061	6	25	60	38	18	-	M6	1	0.30
	HSK40A-EMH8C-60	P2563062	8	28	60	38	18	-	M8	1	0.30
	HSK40A-EMH10C-60	P2563063	10	35	60	42	20	-	M10	1	0.30
	HSK40A-EMH12C-70	P2563064	12	42	70	47	22.5	-	M12	1	0.40
	HSK40A-EMH14C-70	P2563065	14	44	70	47	22.5	-	M12	1	0.40
50A	HSK40A-EMH16C-80	P2563066	16	48	80	50	24	-	M14	1	0.60
	HSK50A-EMH6C-65	P2563067	6	25	65	38	18	-	M6	1	0.70
	HSK50A-EMH8C-65	P2563068	8	28	65	38	18	-	M8	1	0.80
	HSK50A-EMH10C-65	P2563069	10	35	65	42	20	-	M10	1	0.80
	HSK50A-EMH12C-80	P2563070	12	42	80	47	22.5	-	M12	1	1.20
	HSK50A-EMH14C-80	P2563071	14	44	80	47	22.5	-	M12	1	1.30
	HSK50A-EMH16C-80	P2563072	16	48	80	50	24	-	M14	1	1.30
63A	HSK50A-EMH18C-80	P2563073	18	50	80	50	24	-	M14	1	1.40
	HSK50A-EMH20C-80	P2563074	20	52	80	52	25	-	M16	1	1.50
	HSK63A-EMH6C-65	P2563021	6	25	65	35	18	-	M6	1	0.80
	HSK63A-EMH8C-65	P2563022	8	28	65	38	18	-	M8	1	0.80
	HSK63A-EMH10C-65	P2563023	10	35	65	42	20	-	M10	1	0.90
	HSK63A-EMH12C-80	P2563024	12	42	80	47	22.5	-	M12	1	1.10
	HSK63A-EMH14C-80	P2563025	14	44	80	47	22.5	-	M12	1	1.20
	HSK63A-EMH16C-80	P2563026	16	48	80	50	24	-	M14	1	1.30
	HSK63A-EMH18C-80	P2563027	18	50	80	50	24	-	M14	1	1.40
	HSK63A-EMH20C-80	P2563028	20	52	80	52	25	-	M16	1	1.50
100A	HSK63A-EMH25C-110	P2563029	25	65	110	60	24	25	M18	2	2.30
	HSK63A-EMH32C-110	P2563030	32	72	110	64	24	28	M20	2	2.60
	HSK100A-EMH6C-80	P2563059	6	25	80	35	18	-	M6	1	0.80
	HSK100A-EMH8C-80	P2563060	8	28	80	35	18	-	M8	1	0.80
	HSK100A-EMH10C-80	P2563052	10	35	80	39	20	-	M10	1	0.90
	HSK100A-EMH12C-80	P2563053	12	42	80	47	22.5	-	M12	1	1.10
	HSK100A-EMH14C-80	P2563054	14	44	80	47	22.5	-	M12	1	1.20
	HSK100A-EMH16C-100	P2563055	16	48	100	50	24	-	M14	1	1.30
	HSK100A-EMH18C-100	P2563056	18	50	100	50	24	-	M14	1	1.40
	HSK100A-EMH20C-100	P2563057	20	52	100	52	25	-	M16	1	1.50
	HSK100A-EMH25C-100	P2563058	25	65	100	60	24	25	M18	2	2.30
	HSK100A-EMH32C-100	P2772801	32	72	100	64	24	28	M20	2	2.60
	HSK100A-EMH40C-120	P2772802	40	80	120	74	30	32	M20	2	2.60

► Standard End Mill Holder is for a cutting tool with Weldon shank and End Mill Holder for a cutting tool with Whistle notch is available upon request.

► Combi-style holder with ball jointed clamping screw which can be used with cutting tools with Weldon and Whistle notch shank is available.



END MILL HOLDER & SIDE LOCK ARBOR

EMH

END MILL HOLDER

FRÄSERFUTTER UND FLÄCHENSANNFUTTER
 MANDRIN PORTE FRAISE À QUEUE CYLINDRIQUE, À MÉPLAT
 MANDRINI PORTA FRESA TIPO WELDON
 PORTAFRESAS Y EJES DE SUJECCION LATERAL

**JIS B6339/
MAS 403-BT**

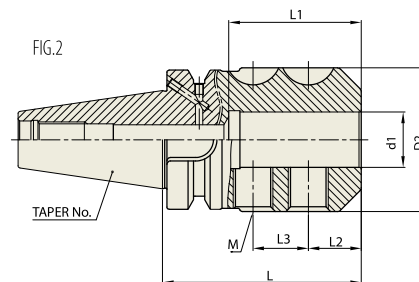
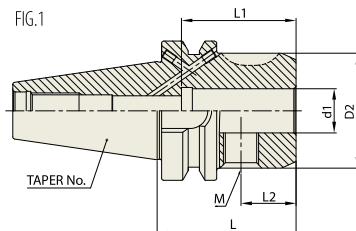

Unit : mm

TAPER No.	MODEL No.	EDP No.	d1	D2	L	L1	L2	L3	M	FIG.	WEIGHT (kg)
30	BT30-EMH6-50	P2772951A	6	25	50	35	18	-	M6	1	0.47
	BT30-EMH8-50	P2772952A	8	28	50	35	18	-	M8	1	0.49
	BT30-EMH10-50	P2772953A	10	35	50	35.5	20	-	M10	1	0.55
	BT30-EMH12-55	P2772954A	12	42	50	36	22.5	-	M12	1	0.67
	BT30-EMH14-55	P2772955A	14	44	55	36	22.5	-	M12	1	0.68
	BT30-EMH16-63	P2772956A	16	48	63	46	24	-	M14	1	0.83
	BT30-EMH18-63	P2772958A	18	50	63	46	24	-	M14	1	0.85
	BT30-EMH20-70	P2772957A	20	52	70	48	25	-	M16	1	0.98
40	BT40AD/B-EMH6-50	P2773031	6	25	50	35	18	-	M6	1	1.00
	BT40AD/B-EMH8-50	P2773032	8	28	50	35	18	-	M8	1	1.00
	BT40AD/B-EMH10-63	P2773033	10	35	63	39	20	-	M10	1	1.10
	BT40AD/B-EMH12-63	P2773034	12	42	63	44	22.5	-	M12	1	1.30
	BT40AD/B-EMH14-63	P2773035	14	44	63	49	22.5	-	M12	1	1.40
	BT40AD/B-EMH16-63	P2773036	16	48	63	52	24	-	M14	1	1.70
	BT40AD/B-EMH18-63	P2773037	18	50	63	50	24	-	M14	1	1.70
	BT40AD/B-EMH20-63	P2773038	20	52	63	52	25	-	M16	1	1.80
	BT40AD/B-EMH25-90	P2773039	25	65	90	60	24	25	M18	2	1.80
	BT40AD/B-EMH32-100	P2773040	32	72	100	64	24	28	M20	2	2.00
50	BT50AD/B-EMH6-63	P2773041	6	25	63	35	18	-	M6	1	3.30
	BT50AD/B-EMH8-63	P2773042	8	28	63	35	18	-	M8	1	3.60
	BT50AD/B-EMH10-65	P2773043	10	35	65	39	20	-	M10	1	3.80
	BT50AD/B-EMH12-80	P2773044	12	42	80	46	22.5	-	M12	1	3.80
	BT40AD/B-EMH14-80	P2773045	14	44	80	46	22.5	-	M12	1	4.00
	BT50AD/B-EMH16-80	P2773046	16	48	80	49	24	-	M14	1	4.00
	BT50AD/B-EMH18-80	P2773047	18	50	80	49	24	-	M14	1	4.20
	BT50AD/B-EMH20-80	P2773048	20	52	80	52	25	-	M16	1	4.20
	BT50AD/B-EMH25-100	P2773049	25	65	100	60	24	25	M18	2	4.60
	BT50AD/B-EMH32-105	P2773050	32	72	105	64	24	28	M20	2	4.70
	BT50AD/B-EMH40-120	P2773051	40	80	120	73	30	32	M20	2	4.90

- ▶ CAT(ANSI B5.50) taper and Inch type products are available.
- ▶ Standard End Mill Holder is for a cutting tool with Weldon shank and End Mill Holder for a cutting tool with Whistle notch is available upon request.
- ▶ Combi-style holder with ball jointed clamping screw which can be used with cutting tools with Weldon and Whistle notch shank is available.



END MILL HOLDER (COOLANT CHANNEL)

FRÄSERFUTTER UND FLÄCHENSANNFUTTER
 MANDRIN PORTE FRAISE À QUEUE CYLINDRIQUE, À MÉPLAT
 MANDRINI PORTA FRESA TIPO WELDON
 PORTAFRESAS Y EJES DE SUJECCION LATERAL

JIS B6339/
 MAS 403-BT

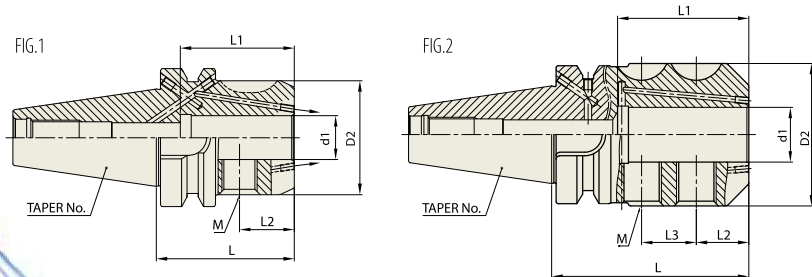
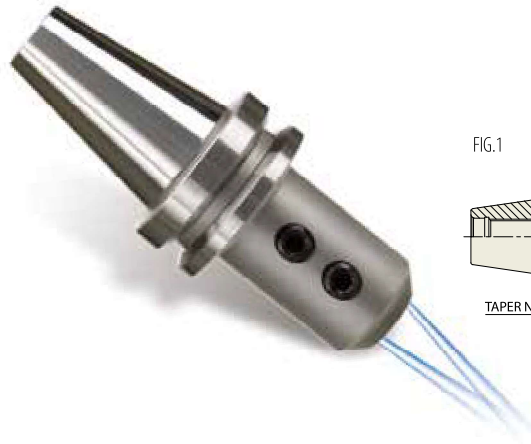

Unit : mm

TAPER No.	MODEL No.	EDP No.	d1	D2	L	L1	L2	L3	M	FIG.	WEIGHT (kg)
40	BT40AD/B-EMH6C-50	P2772991	6	25	50	35	18	-	M6	1	1.00
	BT40AD/B-EMH8C-50	P2772992	8	28	50	35	18	-	M8	1	1.00
	BT40AD/B-EMH10C-63	P2772993	10	35	63	39	20	-	M10	1	1.10
	BT40AD/B-EMH12C-63	P2772994	12	42	63	44	22.5	-	M12	1	1.30
	BT40AD/B-EMH14C-63	P2772995	14	44	63	49	22.5	-	M12	1	1.40
	BT40AD/B-EMH16C-63	P2772996	16	48	63	52	24	-	M14	1	1.70
	BT40AD/B-EMH18C-63	P2772997	18	50	63	50	24	-	M14	1	1.70
	BT40AD/B-EMH20C-63	P2772998	20	52	63	52	25	-	M16	1	1.80
	BT40AD/B-EMH25C-90	P2772999	25	65	90	60	24	25	M18	2	1.80
	BT40AD/B-EMH32C-100	P2773000	32	72	100	64	24	28	M20	2	2.00
50	BT50AD/B-EMH6C-63	P2773012	6	25	63	35	18	-	M6	1	3.30
	BT50AD/B-EMH8C-63	P2773013	8	28	63	35	18	-	M8	1	3.60
	BT50AD/B-EMH10C-65	P2773014	10	35	65	39	20	-	M10	1	3.80
	BT50AD/B-EMH12C-80	P2773015	12	42	80	46	22.5	-	M12	1	3.80
	BT40AD/B-EMH14C-80	P2773016	14	44	80	46	22.5	-	M12	1	4.00
	BT50AD/B-EMH16C-80	P2773017	16	48	80	49	24	-	M14	1	4.00
	BT50AD/B-EMH18C-80	P2773018	18	50	80	49	24	-	M14	1	4.20
	BT50AD/B-EMH20C-80	P2773019	20	52	80	52	25	-	M16	1	4.20
	BT50AD/B-EMH25C-100	P2773020	25	65	100	60	24	25	M18	2	4.60
	BT50AD/B-EMH32C-105	P2773021	32	72	105	64	24	28	M20	2	4.70
	BT50AD/B-EMH40C-120	P2773022	40	80	120	73	30	32	M20	2	4.90

- ▶ CAT(ANSI B5.50) taper and Inch type products are available.
- ▶ Standard End Mill Holder is for a cutting tool with Weldon shank and End Mill Holder for a cutting tool with Whistle notch is available upon request.
- ▶ Combi-style holder with ball jointed clamping screw which can be used with cutting tools with Weldon and Whistle notch shank is available.



END MILL HOLDER & SIDE LOCK ARBOR

EMH

END MILL HOLDER

FRÄSERFUTTER UND FLÄCHENSPIANNFUTTER
 MANDRIN PORTE FRAISE À QUEUE CYLINDRIQUE, À MÉPLAT
 MANDRINI PORTA FRESA TIPO WELDON
 PORTAFRESAS Y EJES DE SUJECCION LATERAL

**JIS B6339/
MAS 403-BT**

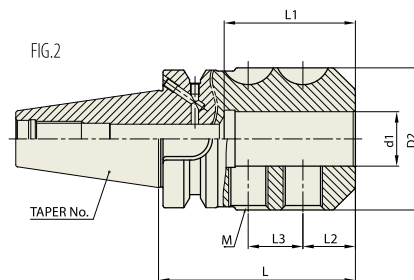
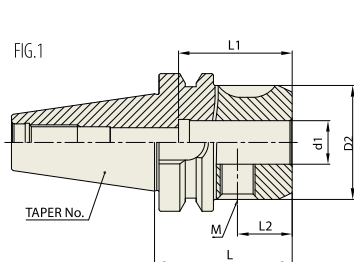

Unit : mm

TAPER No.	MODEL No.	EDP No.	d1	D2	L	L1	L2	L3	M	FIG.	WEIGHT (kg)
30	BT30-EMH6-50	P2776227A	6	25	50	35	18	-	M6	1	0.47
	BT30-EMH8-50	P2776228A	8	28	50	35	18	-	M8	1	0.49
	BT30-EMH10-50	P2776229A	10	35	50	35.5	20	-	M10	1	0.55
	BT30-EMH12-55	P2776230A	12	42	50	36	22.5	-	M12	1	0.67
	BT30-EMH14-55	P2776231A	14	44	55	36	22.5	-	M12	1	0.68
	BT30-EMH16-63	P2776201A	16	48	63	46	24	-	M14	1	0.83
	BT30-EMH18-63	P2776232A	18	50	63	46	24	-	M14	1	0.85
	BT30-EMH20-70	P2776202A	20	52	70	48	25	-	M16	1	0.98
40	BT40-EMH6-50	P2773061	6	25	50	35	18	-	M6	1	1.00
	BT40-EMH8-50	P2773062	8	28	50	35	18	-	M8	1	1.00
	BT40-EMH10-63	P2773063	10	35	63	39	20	-	M10	1	1.10
	BT40-EMH12-63	P2773064	12	42	63	44	22.5	-	M12	1	1.30
	BT40-EMH14-63	P2773065	14	44	63	49	22.5	-	M12	1	1.40
	BT40-EMH16-63	P2773066	16	48	63	52	24	-	M14	1	1.70
	BT40-EMH18-63	P2773067	18	50	63	50	24	-	M14	1	1.70
	BT40-EMH20-63	P2773068	20	52	63	52	25	-	M16	1	1.80
	BT40-EMH25-90	P2773069	25	65	90	60	24	25	M18	2	1.80
	BT40-EMH32-100	P2773070	32	72	100	64	24	28	M20	2	2.00
50	BT50-EMH6-63	P2773071	6	25	63	35	18	-	M6	1	3.30
	BT50-EMH8-63	P2773072	8	28	63	35	18	-	M8	1	3.60
	BT50-EMH10-65	P2773073	10	35	65	39	20	-	M10	1	3.80
	BT50-EMH12-80	P2773074	12	42	80	46	22.5	-	M12	1	3.80
	BT50-EMH14-80	P2773075	14	44	80	46	22.5	-	M12	1	4.00
	BT50-EMH16-80	P2773076	16	48	80	49	24	-	M14	1	4.00
	BT50-EMH18-80	P2773077	18	50	80	49	24	-	M14	1	4.20
	BT50-EMH20-80	P2773078	20	52	80	52	25	-	M16	1	4.20
	BT50-EMH25-100	P2773079	25	65	100	60	24	25	M18	2	4.60
	BT50-EMH32-105	P2773080	32	72	105	64	24	28	M20	2	4.70
	BT50-EMH40-120	P2773081	40	80	120	73	30	32	M20	2	4.90

- ▶ CAT(ANSI B5.50) taper and Inch type products are available.
- ▶ Standard End Mill Holder is for a cutting tool with Weldon shank and End Mill Holder for a cutting tool with Whistle notch is available upon request.
- ▶ Combi-style holder with ball jointed clamping screw which can be used with cutting tools with Weldon and Whistle notch shank is available.

YG END MILL HOLDER & SIDE LOCK ARBOR

EMH

END MILL HOLDER

FRÄSERFUTTER UND FLÄCHENSPIANNFUTTER
 MANDRIN PORTE FRAISE À QUEUE CYLINDRIQUE, À MÉPLAT
 MANDRINI PORTA FRESA TIPO WELDON
 PORTAFRESAS Y EJES DE SUJECCION LATERAL

JIS B6339/
 MAS 403-BT

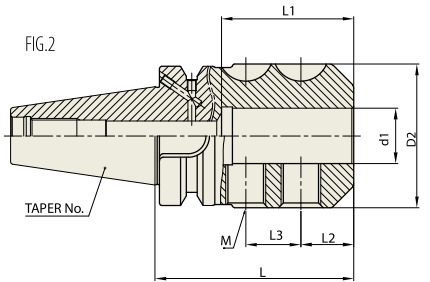
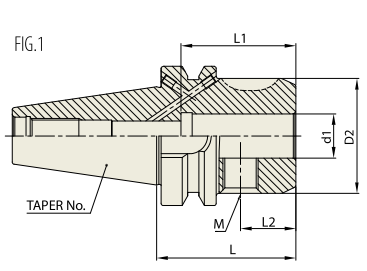

											Unit : mm
TAPER No.	MODEL No.	EDP No.	d1	D2	L	L1	L2	L3	M	FIG.	WEIGHT (kg)
40	BT40AD/B-EMH6-50	P2780301	6	25	50	35	18	-	M6	1	1.00
	BT40AD/B-EMH8-50	P2780302	8	28	50	35	18	-	M8	1	1.00
	BT40AD/B-EMH10-63	P2780303	10	35	63	39	20	-	M10	1	1.10
	BT40AD/B-EMH12-63	P2780304	12	42	63	44	22.5	-	M12	1	1.30
	BT40AD/B-EMH14-63	P2780305	14	44	63	49	22.5	-	M12	1	1.40
	BT40AD/B-EMH16-63	P2780306	16	48	63	52	24	-	M14	1	1.70
	BT40AD/B-EMH18-63	P2780307	18	50	63	50	24	-	M14	1	1.70
	BT40AD/B-EMH20-63	P2780308	20	52	63	52	25	-	M16	1	1.80
	BT40AD/B-EMH25-90	P2780309	25	65	90	60	24	25	M18	2	1.80
	BT40AD/B-EMH32-100	P2780310	32	72	100	64	24	28	M20	2	2.00
50	BT50AD/B-EMH6-63	P2780311	6	25	63	35	18	-	M6	1	3.30
	BT50AD/B-EMH8-63	P2780312	8	28	63	35	18	-	M8	1	3.60
	BT50AD/B-EMH10-65	P2780313	10	35	65	39	20	-	M10	1	3.80
	BT50AD/B-EMH12-80	P2780314	12	42	80	46	22.5	-	M12	1	3.80
	BT50AD/B-EMH14-80	P2780315	14	44	80	46	22.5	-	M12	1	4.00
	BT50AD/B-EMH16-80	P2780316	16	48	80	49	24	-	M14	1	4.00
	BT50AD/B-EMH18-80	P2780317	18	50	80	49	24	-	M14	1	4.20
	BT50AD/B-EMH20-80	P2780318	20	52	80	52	25	-	M16	1	4.20
	BT50AD/B-EMH25-100	P2780319	25	65	100	60	24	25	M18	2	4.60
	BT50AD/B-EMH32-105	P2780320	32	72	105	64	24	28	M20	2	4.70
	BT50AD/B-EMH40-120	P2780321	40	80	120	73	30	32	M20	2	4.90

- ▶ CAT(ANSI B5.50) taper and Inch type products are available.
- ▶ Standard End Mill Holder is for a cutting tool with Weldon shank and End Mill Holder for a cutting tool with Whistle notch is available upon request.
- ▶ Combi-style holder with ball jointed clamping screw which can be used with cutting tools with Weldon and Whistle notch shank is available.



END MILL HOLDER & SIDE LOCK ARBOR

EMH

END MILL HOLDER (COOLANT CHANNEL)

FRÄSERFUTTER UND FLÄCHENSPIANNFUTTER
 MANDRIN PORTE FRAISE À QUEUE CYLINDRIQUE, À MÉPLAT
 MANDRINI PORTA FRESA TIPO WELDON
 PORTAFRESAS Y EJES DE SUJECCION LATERAL

**JIS B6339/
MAS 403-BT**

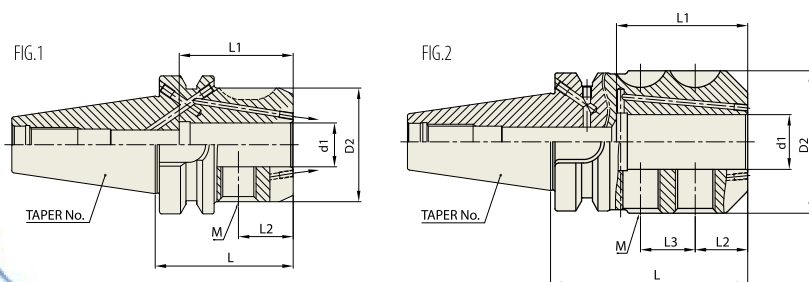

Unit : mm

TAPER No.	MODEL No.	EDP No.	d1	D2	L	L1	L2	L3	M	FIG.	WEIGHT (kg)
40	BT40AD/B-EMH6C-50	P2778001	6	25	50	35	18	-	M6	1	1.00
	BT40AD/B-EMH8C-50	P2778002	8	28	50	35	18	-	M8	1	1.00
	BT40AD/B-EMH10C-63	P2778003	10	35	63	39	20	-	M10	1	1.10
	BT40AD/B-EMH12C-63	P2778004	12	42	63	44	22.5	-	M12	1	1.30
	BT40AD/B-EMH14C-63	P2778005	14	44	63	49	22.5	-	M12	1	1.40
	BT40AD/B-EMH16C-63	P2778006	16	48	63	52	24	-	M14	1	1.70
	BT40AD/B-EMH18C-63	P2778007	18	50	63	50	24	-	M14	1	1.70
	BT40AD/B-EMH20C-63	P2778008	20	52	63	52	25	-	M16	1	1.80
	BT40AD/B-EMH25C-90	P2778009	25	65	90	60	24	25	M18	2	1.80
	BT40AD/B-EMH32C-100	P2778010	32	72	100	64	24	28	M20	2	2.00
50	BT50AD/B-EMH6C-63	P2778011	6	25	63	35	18	-	M6	1	3.30
	BT50AD/B-EMH8C-63	P2778012	8	28	63	35	18	-	M8	1	3.60
	BT50AD/B-EMH10C-65	P2778013	10	35	65	39	20	-	M10	1	3.80
	BT50AD/B-EMH12C-80	P2778014	12	42	80	46	22.5	-	M12	1	3.80
	BT50AD/B-EMH14C-80	P2778015	14	44	80	46	22.5	-	M12	1	4.00
	BT50AD/B-EMH16C-80	P2778016	16	48	80	49	24	-	M14	1	4.00
	BT50AD/B-EMH18C-80	P2778017	18	50	80	49	24	-	M14	1	4.20
	BT50AD/B-EMH20C-80	P2778018	20	52	80	52	25	-	M16	1	4.20
	BT50AD/B-EMH25C-100	P2778019	25	65	100	60	24	25	M18	2	4.60
	BT50AD/B-EMH32C-105	P2778020	32	72	105	64	24	28	M20	2	4.70
BT50AD/B-EMH40C-120	P2778021	40	80	120	73	30	32	M20	2	4.90	

- ▶ CAT(ANSI B5.50) taper and Inch type products are available.
- ▶ Standard End Mill Holder is for a cutting tool with Weldon shank and End Mill Holder for a cutting tool with Whistle notch is available upon request.
- ▶ Combi-style holder with ball jointed clamping screw which can be used with cutting tools with Weldon and Whistle notch shank is available.

TOOLING SYSTEM

HYDRAULIC CHUCK

SHRINK FIT HOLDER

ER COLLET CHUCK

END MILL HOLDER & SIDE LOCK ARBOR

SHELL MILL ARBOR

POWER MILLING CHUCK

MORSE TAPER ARBOR

SK SLIM CHUCK

SYNCHRO TAPPING CHUCK

ONE STEP TAPPING CHUCK

TAPPING ER CHUCK

TAPPING CHUCK

FACE MILL ARBOR

COPY MILL ARBOR & INDEXABLE DRILL HOLDER

NC DRILL CHUCK & OTHER TOOL HOLDERS

BORING SYSTEM

ACCESSORY & OTHERS

YIG END MILL HOLDER & SIDE LOCK ARBOR

EMH

END MILL HOLDER (SHORT TYPE)

DIN 69871-SK

FRÄSERFUTTER UND FLÄCHENSANNFUTTER
 MANDRIN PORTE FRAISE À QUEUE CYLINDRIQUE, À MÉPLAT
 MANDRINI PORTA FRESA TIPO WELDON
 PORTAFRESAS Y EJES DE SUJECCION LATERAL

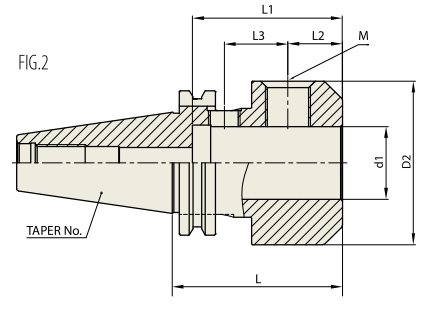
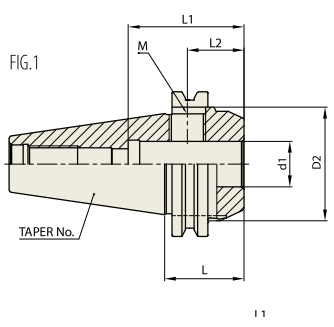

											Unit : mm
TAPER No.	MODEL No.	EDP No.	d1	D2	L	L1	L2	L3	M	FIG.	WEIGHT (kg)
40	SK40-EMH16-35	P2521001	16	48	35	51	24	-	M14	1	0.80
	SK40-EMH20-35	P2521027	20	50	35	51	25	-	M16	1	0.90
	SK40-EMH25-60	P2521003	25	50	60	59	24	25	M18/M14	2	1.20
	SK40-EMH32-75	P2521030	32	72	75	66	24	28	M20/M14	2	1.80
50	SK50-EMH25-60	P2521031	25	65	60	60	23.5	25.4	M18/M14	2	3.35
	SK50-EMH32-60	P2521032	32	72	60	63	24	24.9	M20/M14	2	3.50

JIS B6339/MAS 403-BT

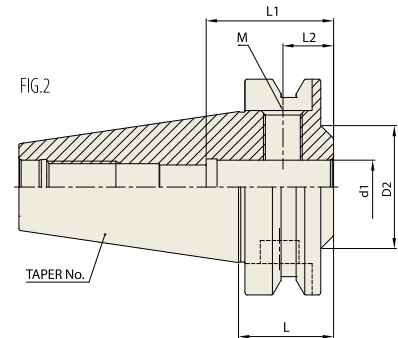
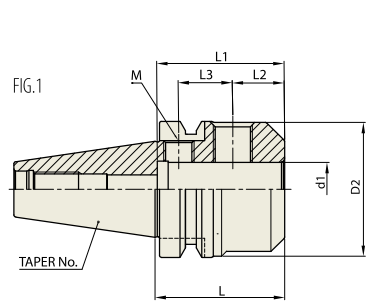

											Unit : mm
TAPER No.	MODEL No.	EDP No.	d1	D2	L	L1	L2	L3	M	FIG.	WEIGHT (kg)
40	BT40-EMH25-60	P2773085	25	62	60	59	24	25	M18	1	1.50
	BT40-EMH32-65	P2773086	32	62	65	63	24	28	M20	1	1.45
50	BT50-EMH25-44	P2773087	25	57	44	59	24	-	M18	2	3.45
	BT50-EMH32-60	P2773088	32	72	60	63	24	28	M20/M14	1	3.80

►Standard End Mill Holder is for a cutting tool with Weldon shank and End Mill Holder for a cutting tool with Whistle notch is available upon request.



END MILL HOLDER & SIDE LOCK ARBOR

EMH

END MILL HOLDER

GOST 25827-93

FRÄSERFUTTER UND FLÄCHENSpanNFUTTER
 MANDRIN PORTE FRAISE À QUEUE CYLINDRIQUE, À MÉPLAT
 MANDRINI PORTA FRESA TIPO WELDON
 PORTAFRESAS Y EJES DE SUJECCION LATERAL

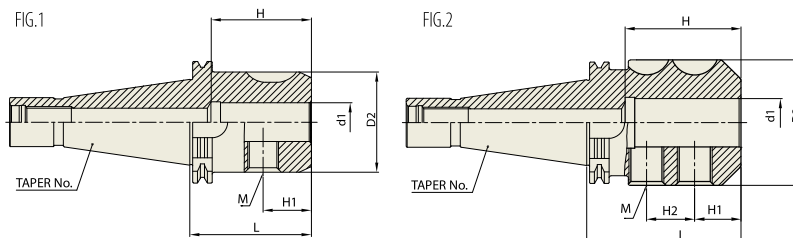

Unit : mm

TAPER No.	MODEL No.	EDP No.	d1	D2	L	H	H1	H2	M	FIG.	WEIGHT (kg)
40	6-50	P2780361	6	25	50	35	18	-	M6	1	
	GOST40-EMH8-50	P2780362	8	28	50	35	18	-	M8	1	
	GOST40-EMH10-50	P2780363	10	35	50	35.5	20	-	M10	1	
	GOST40-EMH12-50	P2780364	12	42	50	36	22.5	-	M12	1	
	GOST40-EMH14-63	P2780365	14	44	63	36	22.5	-	M12	1	
	GOST40-EMH16-63	P2780366	16	48	63	46	24	-	M14	1	
	GOST40-EMH18-63	P2780367	18	50	63	46	24	-	M14	1	
	GOST40-EMH20-63	P2780368	20	52	63	48	25	-	M16	1	
	GOST40-EMH25-80	P2780369	25	65	80	55	24	25	M18	2	
	GOST40-EMH32-80	P2780370	32	72	80	57	24	28	M20	2	
50	GOST50-EMH6-63	P2780371	6	25	63	35	18	-	M6	1	
	GOST50-EMH8-63	P2780372	8	28	63	35	18	-	M8	1	
	GOST50-EMH10-63	P2780373	10	35	63	35.5	20	-	M10	1	
	GOST50-EMH12-63	P2780374	12	42	63	36	22.5	-	M12	1	
	GOST50-EMH14-63	P2780375	14	44	63	36	22.5	-	M12	1	
	GOST50-EMH16-63	P2780376	16	48	63	46	24	-	M14	1	
	GOST50-EMH18-63	P2780377	18	50	63	46	24	-	M14	1	
	GOST50-EMH20-63	P2780378	20	52	63	48	25	-	M16	1	
	GOST50-EMH25-80	P2780379	25	65	80	55	24	25	M18	2	
	GOST50-EMH32-80	P2780380	32	72	80	63	24	28	M20	2	
	GOST50-EMH40-90	P2780381	40	80	90	68	30	32	M20	2	

TOOLING SYSTEM

HYDRAULIC CHUCK

SHRINK FIT HOLDER

ER COLLET CHUCK

END MILL HOLDER & SIDE LOCK ARBOR

SHELL MILL ARBOR

POWER MILLING CHUCK

MORSE TAPER ARBOR

SK SLIM CHUCK

SYNCHRO TAPPING CHUCK

ONE STEP TAPPING CHUCK

TAPPING ER CHUCK

TAPPING CHUCK

FACE MILL ARBOR

COPY MILL ARBOR & INDEXABLE DRILL HOLDER

NC DRILL CHUCK & OTHER TOOL HOLDERS

BORING SYSTEM

ACCESSORY & OTHERS

YG END MILL HOLDER & SIDE LOCK ARBOR

SLA

SIDE LOCK ARBOR

FRÄSERFUTTER UND FLÄCHENSPANNFUTTER
 MANDRIN PORTE FRAISE À QUEUE CYLINDRIQUE, À MÉPLAT
 MANDRINI PORTA FRESA TIPO WELDON
 PORTAFRESAS Y EJES DE SUJECCION LATERAL

CBT
 (BT DUAL CONTACT)

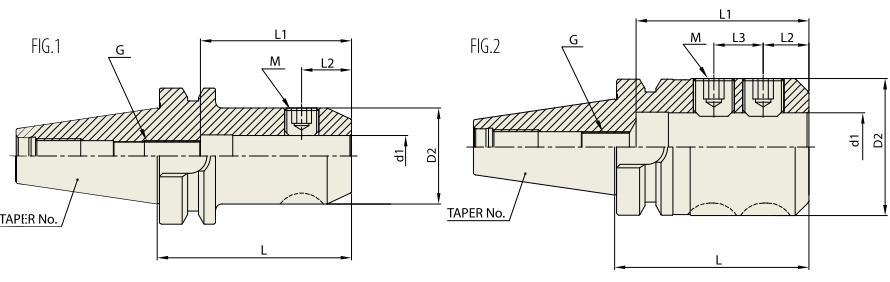

											Unit : mm
TAPER No.	MODEL No.	EDP No.	d1	D2	L	L1	L2	L3	M	FIG.	WEIGHT (kg)
30	CBT30-SLA6-60	P2772918	6	25	60	35	18	-	M5	1	0.70
	CBT30-SLA8-60	P2772919	8	28	60	35	18	-	M6	1	0.80
	CBT30-SLA10-60	P2772920	10	35	60	40	14	13	M8	2	0.90
	CBT30-SLA12-60	P2772921	12	40	60	50	14	13	M10	2	1.10
	CBT30-SLA14-60	P2772922	14	40	60	50	14	13	M10	2	1.20
	CBT30-SLA16-75	P2772923	16	40	75	70	25	20	M12	2	1.30
	CBT30-SLA20-75	P2772924	20	50	75	70	25	20	M12	2	1.40
	CBT30-SLA25-75	P2772925	25	50	75	70	25	20	M14	2	1.50
40	CBT30-SLA32-105	P2772926	32	60	105	80	25	25	M16	2	1.60
	CBT40-SLA6-60	P2772927	6	25	60	35	18	-	M5	1	1.10
	CBT40-SLA8-60	P2772928	8	28	60	35	18	-	M6	1	1.10
	CBT40-SLA10-60	P2772929	10	35	60	50	14	13	M8	2	1.20
	CBT40-SLA12-60	P2772930	12	40	60	50	14	13	M10	2	1.40
	CBT40-SLA16-90	P2772931	16	40	90	70	25	20	M12	2	1.50
	CBT40-SLA20-90	P2772901	20	50	90	70	25	20	M12	2	1.80
	CBT40-SLA25-90	P2772902	25	50	90	70	25	20	M14	2	1.70
	CBT40-SLA32-90	P2772903	32	60	90	80	25	25	M16	2	1.90
	CBT40-SLA40-90	P2772904	40	63	90	80	25	25	M16	2	1.80
50	CBT40-SLA42-90	P2772905	42	63	90	80	25	25	M16	2	1.80
	CBT50-SLA6-90	P2772906	6	25	90	40	18	-	M5	1	3.70
	CBT50-SLA8-90	P2772907	8	28	90	40	18	-	M6	1	3.90
	CBT50-SLA10-90	P2772908	10	35	90	50	15	15	M8	2	4.10
	CBT50-SLA12-90	P2772909	12	40	90	55	15	15	M10	2	4.30
	CBT50-SLA14-90	P2772910	14	40	90	55	15	15	M10	2	4.30
	CBT50-SLA16-105	P2772911	16	40	105	70	25	20	M12	2	4.40
	CBT50-SLA20-105	P2772912	20	50	105	70	25	20	M12	2	4.80
	CBT50-SLA25-105	P2772913	25	50	105	70	25	20	M14	2	4.70
	CBT50-SLA32-105	P2772914	32	60	105	80	25	25	M14	2	4.00
	CBT50-SLA40-105	P2772915	40	63	105	80	25	25	M16	2	4.50
	CBT50-SLA42-105	P2772916	42	63	105	80	25	25	M16	2	4.70
	CBT50-SLA50.8-121	P2772917	50.8	95	121	87	33.9	35.8	M20	2	5.00

▶ Standard End Mill Holder is for a cutting tool with Weldon shank and End Mill Holder for a cutting tool with Whistle notch is available upon request.
 ▶ Side Lock Arbor is Non-Balancing.



END MILL HOLDER & SIDE LOCK ARBOR

SLA

SIDE LOCK ARBOR

FRÄSERFUTTER UND FLÄCHENSPIANNFUTTER
 MANDRIN PORTE FRAISE À QUEUE CYLINDRIQUE, À MÉPLAT
 MANDRINI PORTA FRESA TIPO WELDON
 PORTAFRESAS Y EJES DE SUJECCION LATERAL

JIS B6339/
 MAS 403-BT

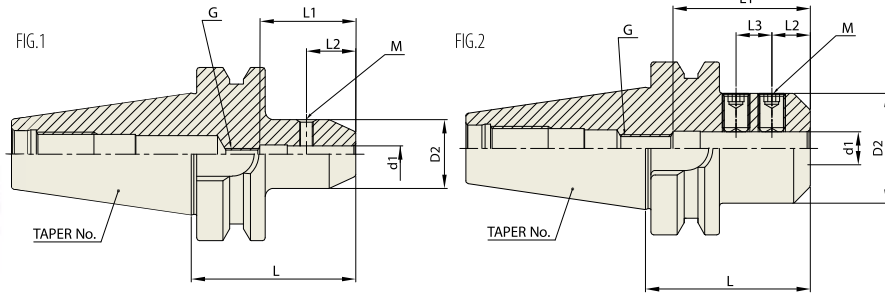

Unit : mm

TAPER No.	MODEL No.	EDP No.	d1	D2	L	L1	L2	L3	M	G	FIG.	WEIGHT (kg)
30	BT30-SLA 6-60	P2780201	6	25	60	35	18	-	M5	M5	1	0.70
	BT30-SLA 8-60	P2780202	8	28	60	35	18	-	M6	M6	1	0.80
	BT30-SLA10-60	P2780203	10	35	60	40	14	13	M8	M8	2	0.90
	BT30-SLA12-60	P2780204	12	40	60	50	14	13	M10	M10	2	1.10
	BT30-SLA14-60	P2780205	14	40	60	50	14	13	M10	M10	2	1.20
	BT30-SLA16-75	P2780206	16	40	75	70	25	20	M12	M12	2	1.30
	BT30-SLA20-75	P2780207	20	50	75	70	25	20	M12	M12	2	1.40
	BT30-SLA25-75	P2780208	25	50	75	70	25	20	M14	M12	2	1.50
40	BT30-SLA32-105	P2780209	32	60	105	80	25	25	M16	M12	2	1.60
	BT40-SLA6-60	P2780210	6	25	60	35	18	-	M5	M5	1	1.10
	BT40-SLA8-60	P2780211	8	28	60	35	18	-	M6	M6	1	1.10
	BT40-SLA10-60	P2780212	10	35	60	50	14	13	M8	M8	2	1.20
	BT40-SLA12-60	P2780213	12	40	60	50	14	13	M10	M10	2	1.40
	BT40-SLA16-90	P2780214	16	40	90	70	25	20	M12	M12	2	1.50
	BT40-SLA20-90	P2780215	20	50	90	70	25	20	M12	M12	2	1.80
	BT40-SLA25-90	P2780216	25	50	90	70	25	20	M14	M12	2	1.70
	BT40-SLA32-90	P2780217	32	60	90	80	25	25	M16	M12	2	1.90
	BT40-SLA40-90	P2780218	40	63	90	80	25	25	M16	M12	2	1.80
50	BT40-SLA42-90	P2780219	42	63	90	80	25	25	M16	M12	2	1.80
	BT50-SLA6-90	P2780220	6	25	90	40	18	-	M5	M5	1	3.70
	BT50-SLA8-90	P2780221	8	28	90	40	18	-	M6	M6	1	3.90
	BT50-SLA10-90	P2780222	10	35	90	50	15	15	M8	M8	2	4.10
	BT50-SLA12-90	P2780223	12	40	90	55	15	15	M10	M10	2	4.30
	BT50-SLA14-90	P2780224	14	40	90	55	15	15	M10	M12	2	4.30
	BT50-SLA16-105	P2780225	16	40	105	70	25	20	M12	M12	2	4.40
	BT50-SLA20-105	P2780226	20	50	105	70	25	20	M12	M12	2	4.80
	BT50-SLA25-105	P2780227	25	50	105	70	25	20	M14	M12	2	4.70
	BT50-SLA32-105	P2780228	32	60	105	80	25	25	M16	M12	2	4.00
	BT50-SLA40-105	P2780229	40	63	105	80	25	25	M16	M12	2	4.50
	BT50-SLA42-105	P2780230	42	63	105	80	25	25	M16	M12	2	4.70
	BT50-SLA50.8-121	P2780231	50.8	95	121	87	33.9	35.8	M20	-	2	5.00

- ▶ CAT(ANSI B5.50) taper and Inch type products are available.
- ▶ Standard End Mill Holder is for a cutting tool with Weldon shank and End Mill Holder for a cutting tool with Whistle notch is available upon request.
- ▶ Side Lock Arbor is Non-Balancing.



SIDE LOCK ARBOR

FRÄSERFUTTER UND FLÄCHENSpanNFUTTER
 MANDRIN PORTE FRAISE À QUEUE CYLINDRIQUE, À MÉPLAT
 MANDRINI PORTA FRESA TIPO WELDON
 PORTAFRESAS Y EJES DE SUJECCION LATERAL

JIS B6339/
 MAS 403-BT

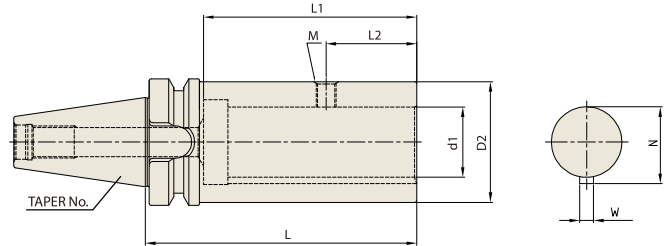

Unit : mm

TAPER No.	MODEL No.	EDP No.	d1	D2	L	L1	L2	M	N	W	WEIGHT (kg)
40	BT40-SLB26-105	P2778051	26	50	105	85	40	M10	28.2	5	1.30
	BT40-SLB35-135	P2778052	35	60	135	105	55	M10	37.6	6	2.20
	BT40-SLB35T-135	P2778053	35	60	135	105	55	M10	38.2	7	2.20
50	BT50-SLB26-105	P2778054	26	50	105	85	40	M10	28.2	5	1.30
	BT50-SLB35-135	P2778055	35	60	135	106	55	M10	37.6	6	2.20
	BT50-SLB35T-135	P2778056	35	60	135	106	55	M10	38.2	7	2.20
	BT50-SLB48-165	P2778057	12	42	165	129	65	M10	51	8	3.80

- ▶ Standard design of side lock arbor is for cutting tools with straight shank having flat face.
- ▶ Side Lock Arbor is Non-Balancing.



END MILL HOLDER & SIDE LOCK ARBOR

PART

SIDE LOCK BOLT

(for END MILL HOLDER & SIDE LOCK ARBOR)

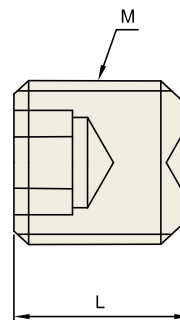
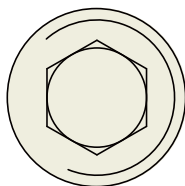

Unit : mm

SLA & EMH ID	EMH			SLA		
	M	L	EDP No.	M	L	EDP No.
6	M6 x 1.0	10.5	P2778088	M5 x 0.8	8	P2778079
8	M8 x 1.25	10.5	P2778089	M6 x 1.0	10	P2778080
10	M10 x 1.5	12.5	P2778090	M8 x 1.25	12	P2778081
12	M12 x 1.75	16.5	P2778091	M10 x 1.5	14	P2778082
14	M12 x 1.75	15.0	P2778092	M10 x 1.5	14	P2778082
16	M14 x 2.0	16.5	P2778093	M12 x 1.75	12	P2778083
18	M14 x 2.0	16.5	P2778093	-	-	-
20	M16 x 2.0	16.5	P2778094	M12 x 1.75	16	P2778084
25	M18 x 2.0	20.5	P2778095	M14 x 2.0	14	P2778085
32	M20 x 2.0	20.5	P2778096	M16 x 2.0	16	P2778086
40	M20 x 2.0	20.5	P2778096	M16 x 2.0	16	P2778086
42	-	-	-	M16 x 2.0	16	P2778086
50	M24 x 2.0	25.5	P2778098	-	-	-
50.8	-	-	-	M20 x 2.5	25	P2778087

TOOLING
SYSTEM

HYDRAULIC
CHUCK

SHRINK FIT
HOLDER

ER COLLET
CHUCK

END MILL
HOLDER &
SIDE LOCK
ARBOR

SHELL MILL
ARBOR

POWER
MILLING
CHUCK

MORSE
TAPER
ARBOR

SK SLIM
CHUCK

SYNCHRO
TAPPING
CHUCK

ONE STEP
TAPPING
CHUCK

TAPPING
ER CHUCK

TAPPING
CHUCK

FACE MILL
ARBOR

COPY MILL
ARBOR &
INDEXABLE
DRILL HOLDER

NC DRILL
CHUCK &
OTHER TOOL
HOLDERS

BORING
SYSTEM

ACCESSORY
& OTHERS



Global Cutting Tool Leader **YG-1**

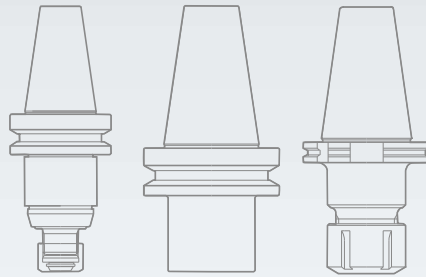

TOOLING SYSTEM