

**YG-1 TOOLING SYSTEM**

# TAPPING ER CHUCK

- ER - GEWINDESCHNEIDFUTTER
- MANDRIN DE TARAUDAGE PINCE ER
- MANDRINI PORTAPINZA ER PER MASCHIATURA
- PORTAPINZAS ER PARA MACHOS



**DIN 69871-SK**

**DIN 69893/ISO 12164-1-HSK**

**CBT (BT DUAL CONTACT)**

**JIS B6339/MAS 403-BT**

## TAPPING ER CHUCK

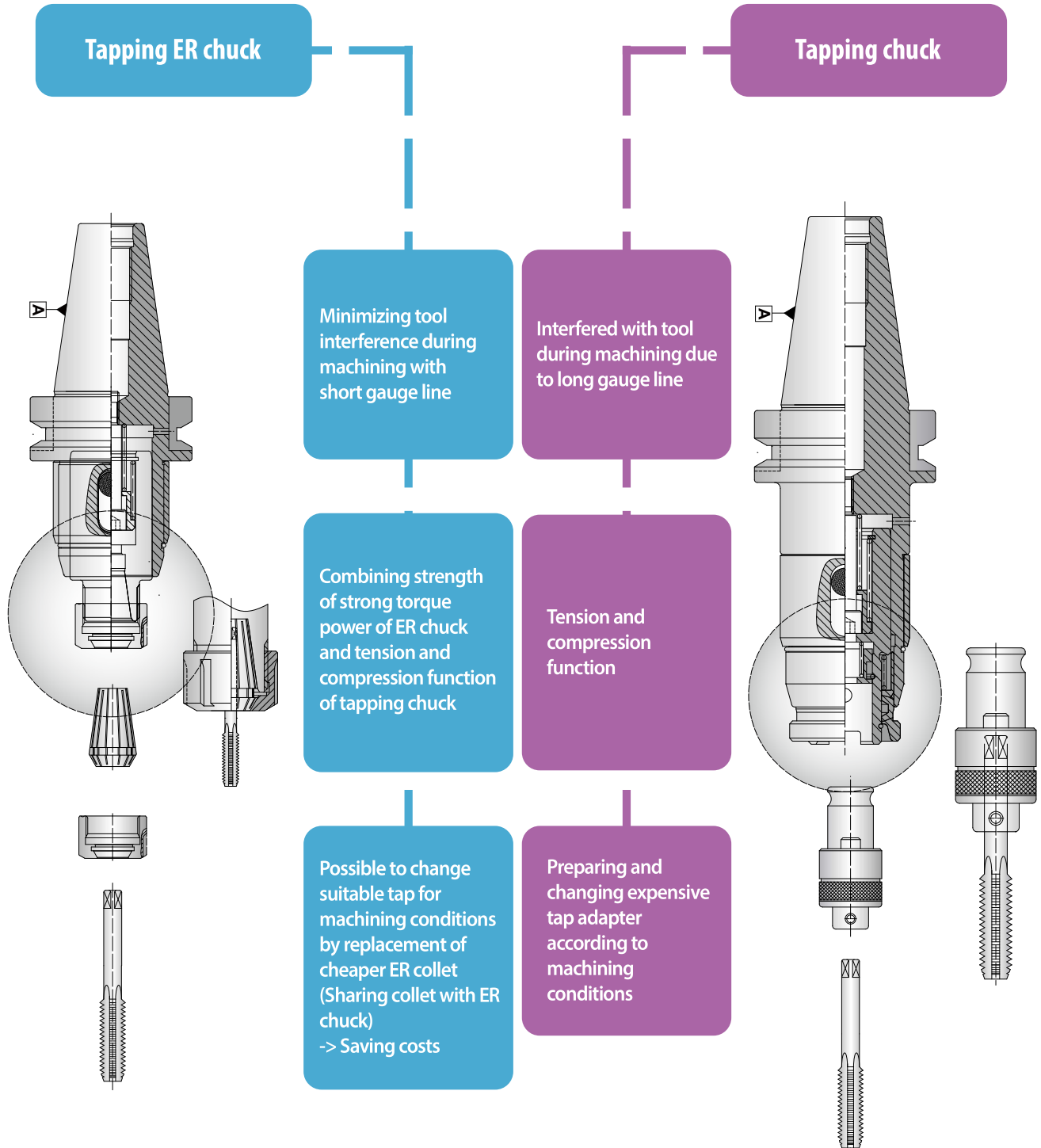

**TAPPING ER CHUCK**

**DIN 69871-SK**

ER - GEWINDESCHNEIDFUTTER  
 MANDRIN DE TARAUDAGE PINCE ER  
 MANDRINI PORTAPINZA ER PER MASCHIATURA  
 PORTAPINZAS ER PARA MACHOS

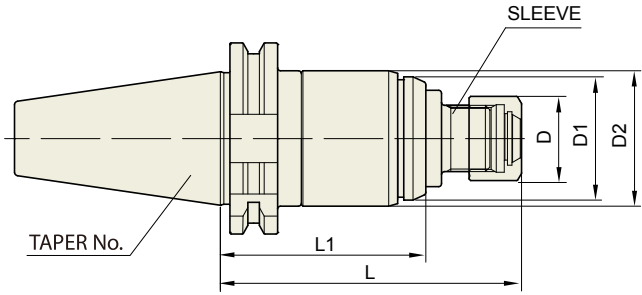

ER collet refer to page 103-107  
 Tap ER collet refer to page 108-109

Unit : mm

TAPER No.	MODEL No.	EDP No.	D	D1	D2	L	L1	NUT	WEIGHT (kg)
40	SK40-TER16-100	P2774001	28	41	45	100	68.4	ER16	1.65
	SK40-TER16-150	P2774002	28	41	45	150	118.4	ER16	1.85
	SK40-TER32-130	P2774003	50	58	63	130	92	ER32	2.10
	SK40-TER32-150	P2774004	50	58	63	150	112	ER32	2.30
50	SK50-TER16-115	P2774005	28	41	45	115	79.4	ER16	4.30
	SK50-TER16-150	P2774006	28	41	45	150	114.4	ER16	4.50
	SK50-TER32-120	P2774007	50	58	63	120	83	ER32	4.65
	SK50-TER32-150	P2774008	50	58	63	150	113	ER32	4.85

► CAT(ANSI B5.50) taper and Inch type products are available.

TOOLING SYSTEM

HYDRAULIC CHUCK

SHRINK FIT HOLDER

ER COLLET CHUCK

END MILL HOLDER & SIDE LOCK ARBOR

SHELL MILL ARBOR

POWER MILLING CHUCK

MORSE TAPER ARBOR

SK SLIM CHUCK

SYNCHRO TAPPING CHUCK

ONE STEP TAPPING CHUCK

TAPPING ER CHUCK

TAPPING CHUCK

FACE MILL ARBOR

COPY MILL ARBOR & INDEXABLE DRILL HOLDER

NC DRILL CHUCK & OTHER TOOL HOLDERS

BORING SYSTEM

ACCESSORY & OTHERS

# YIG TAPPING ER CHUCK

**TER**

## TAPPING ER CHUCK

**DIN 69893/ ISO 12164-1-HSK FORM A**

ER - GEWINDESCHNEIDFUTTER  
 MANDRIN DE TARAUDAGE PINCE ER  
 MANDRINI PORTAPINZA ER PER MASCHIATURA  
 PORTAPINZAS ER PARA MACHOS

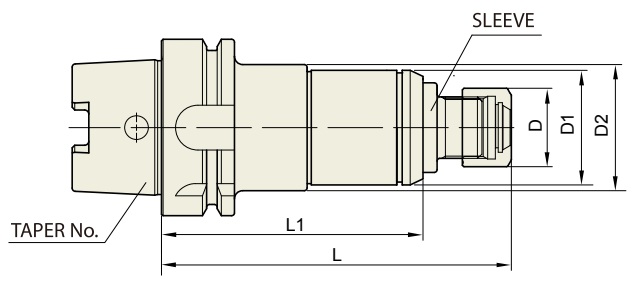

ER collet refer to page 103-107  
 Tap ER collet refer to page 108-109

Unit : mm

TAPER No.	MODEL No.	EDP No.	D	D1	D2	L	L1	NUT	WEIGHT (kg)
50A	HSK50A-TER16-125	P2774107	28	41	45	125	93.4	ER16	1.20
	HSK50A-TER16-150	P2774108	28	41	45	150	118.4	ER16	1.30
63A	HSK63A-TER16-125	P2774101	28	41	45	125	93.4	ER16	1.70
	HSK63A-TER16-150	P2774102	28	41	45	150	118.4	ER16	1.85
	HSK63A-TER32-150	P2774103	50	58	63	150	112	ER32	2.10
	HSK63A-TER32-180	P2774109	50	58	63	180	142	ER32	2.30
100A	HSK100A-TER16-130	P2774104	28	41	45	130	98.4	ER16	4.00
	HSK100A-TER16-150	P2774105	28	41	45	150	118.4	ER16	4.20
	HSK100A-TER32-150	P2774106	50	58	63	150	112	ER32	4.40
	HSK100A-TER32-180	P2774110	50	58	63	180	142	ER32	4.60

**TAPPING ER CHUCK**

ER - GEWINDESCHNEIDFUTTER  
 MANDRIN DE TARAUDAGE PINCE ER  
 MANDRINI PORTAPINZA ER PER MASCHIATURA  
 PORTAPINZAS ER PARA MACHOS

**CBT**  
**(BT DUAL CONTACT)**

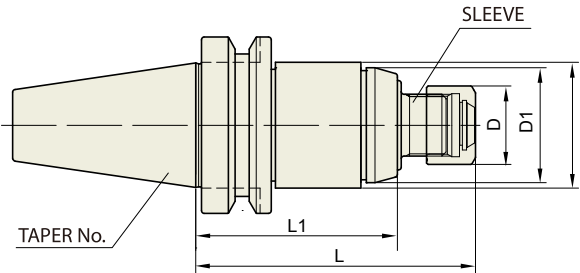

ER collet refer to page 103-107  
 Tap ER collet refer to page 108-109

Unit : mm

TAPER No.	MODEL No.	EDP No.	D	D1	D2	L	L1	NUT	WEIGHT (kg)
40	CBT40-TER16-100	P2774151	28	41	45	100	68.4	ER16	1.45
	CBT40-TER16-150	P2774152	28	41	45	150	118.4	ER16	2.00
	CBT40-TER32-110	P2774153	50	58	63	110	72	ER32	2.20
	CBT40-TER32-150	P2774154	50	58	63	150	112	ER32	2.70
50	CBT50-TER16-115	P2774155	28	41	45	115	79.4	ER16	3.95
	CBT50-TER16-150	P2774156	28	41	45	150	114.4	ER16	4.35
	CBT50-TER32-120	P2774157	50	58	63	120	83	ER32	4.70
	CBT50-TER32-150	P2774158	50	58	63	150	113	ER32	5.20

- TOOLING SYSTEM
- HYDRAULIC CHUCK
- SHRINK FIT HOLDER
- ER COLLET CHUCK
- END MILL HOLDER & SIDE LOCK ARBOR
- SHELL MILL ARBOR
- POWER MILLING CHUCK
- MORSE TAPER ARBOR
- SK SLIM CHUCK
- SYNCHRO TAPPING CHUCK
- ONE STEP TAPPING CHUCK
- TAPPING ER CHUCK
- TAPPING CHUCK
- FACE MILL ARBOR
- COPY MILL ARBOR & INDEXABLE DRILL HOLDER
- NC DRILL CHUCK & OTHER TOOL HOLDERS
- BORING SYSTEM
- ACCESSORY & OTHERS

**TAPPING ER CHUCK**

**JIS B6339/  
MAS 403-BT**

ER - GEWINDESCHNEIDFUTTER  
MANDRIN DE TARAUDAGE PINCE ER  
MANDRINI PORTAPINZA ER PER MASCHIATURA  
PORTAPINZAS ER PARA MACHOS

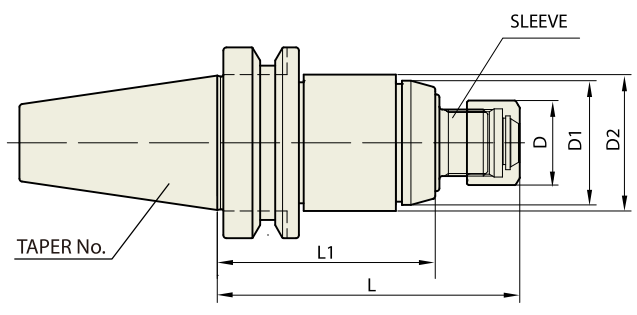

ER collet refer to page 103-107  
Tap ER collet refer to page 108-109

Unit : mm

TAPER No.	MODEL No.	EDP No.	D	D1	D2	L	L1	NUT	WEIGHT (kg)
40	BT40-TER16-100	P2774159	28	41	45	100	68.4	ER16	1.45
	BT40-TER16-150	P2774160	28	41	45	150	118.4	ER16	2.00
	BT40-TER32-110	P2774161	50	58	63	110	72	ER32	2.20
	BT40-TER32-150	P2774162	50	58	63	150	112	ER32	2.70
50	BT50-TER16-115	P2774163	28	41	45	115	79.4	ER16	3.95
	BT50-TER16-150	P2774164	28	41	45	150	114.4	ER16	4.35
	BT50-TER32-120	P2774165	50	58	63	120	83	ER32	4.70
	BT50-TER32-150	P2774166	50	58	63	150	113	ER32	5.20

► CAT(ANSI B5.50) taper and Inch type products are available.

HYDRAULIC CHUCK  
SHRINK FIT HOLDER  
ER COLLET CHUCK  
END MILL HOLDER & SIDE LOCK ARBOR  
SHELL MILL ARBOR  
POWER MILLING CHUCK  
MORSE TAPER ARBOR  
SK SLIM CHUCK  
SYNCHRO TAPPING CHUCK  
ONE STEP TAPPING CHUCK  
TAPPING ER CHUCK  
TAPPING CHUCK  
FACE MILL ARBOR  
COPY MILL ARBOR & INDEXABLE DRILL HOLDER  
NC DRILL CHUCK & OTHER TOOL HOLDERS  
BORING SYSTEM  
ACCESSORY & OTHERS



# ER COLLET CHUCK

**RDTC**

## TAP ER COLLET (DIN)

ER SPANNZANGE - FÜR GEWINDESCHNEID  
 ER PINCE DE SERRAGE - POUR TARAUDER  
 ER PINZA DI SERRAGGIO - PER MASCHIARE  
 ER PINZA PORTAPIEZAS - PARA HILO

Below standard  
 Tap ER Collet conforms to **DIN**

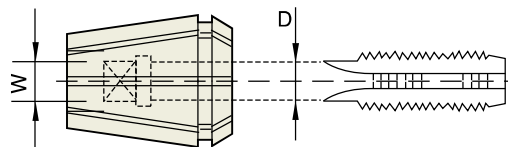

Unit : mm

DIN STANDARD			RD 11TC			RD 16TC			RD 20TC			RD 25TC			RD 32TC			RD 40TC			RD 50TC			
DIN 374/376	DIN 352/2181	DIN 371	D (Ø)	W (□)	EDP No.	D (Ø)	W (□)	EDP No.	D (Ø)	W (□)	EDP No.	D (Ø)	W (□)	EDP No.	D (Ø)	W (□)	EDP No.	D (Ø)	W (□)	EDP No.	D (Ø)	W (□)	EDP No.	
M5	M3	M3	3.5	2.7	P2772501D	3.5	2.7	P2772507D	3.5	2.7	P2772514D	3.5	2.7	P2772524D	3.5	2.7	P2772538D	3.5	2.7	P2772552D				
M5.5	M3.5	M3.5	4.0	3.0	P2772502D	4.0	3.0	P2772508D	4.0	3.0	P2772515D	4.0	3.0	P2772525D	4.0	3.0	P2772539D	4.0	3.0	P2772553D				
M6	M4	M4	4.5	3.4	P2772503D	4.5	3.4	P2772509D	4.5	3.4	P2772516D	4.5	3.4	P2772526D	4.5	3.4	P2772540D	4.5	3.4	P2772554D				
M5	-	-	5.0	4.0	P2772504D	5.0	4.0	P2772510D	5.0	4.0	P2772517D	5.0	4.0	P2772527D	5.0	4.0	P2772541D	5.0	4.0	P2772555D				
M7	-	-	5.5	4.3	P2772505D	5.5	4.3	P2772511D	5.5	4.3	P2772518D	5.5	4.3	P2772528D	5.5	4.3	P2772542D	5.5	4.3	P2772556D				
M8	M4.5-M8	M4.5-M8	6.0	4.9	P2772506D	6.0	4.9	P2772512D	6.0	4.9	P2772519D	6.0	4.9	P2772529D	6.0	4.9	P2772543D	6.0	4.9	P2772557D				
M9+M10	M9+M10	M7				7.0	5.5	P2772513D	7.0	5.5	P2772520D	7.0	5.5	P2772530D	7.0	5.5	P2772544D	7.0	5.5	P2772558D				
M11	M11	M8							8.0	6.2	P2772521D	8.0	6.2	P2772531D	8.0	6.2	P2772545D	8.0	6.2	P2772559D	8.0	6.2	P2772569D	
M12	M12	M9							9.0	7.0	P2772522D	9.0	7.0	P2772532D	9.0	7.0	P2772546D	9.0	7.0	P2772560D	9.0	7.0	P2772570D	
-	-	M10							10.0	8.0	P2772523D	10.0	8.0	P2772533D	10.0	8.0	P2772547D	10.0	8.0	P2772561D	10.0	8.0	P2772571D	
M13+M14	M13+M14	-										11.0	9.0	P2772534D	11.0	9.0	P2772548D	11.0	9.0	P2772562D	11.0	9.0	P2772572D	
M15-M17	M15-M17	-										12.0	9.0	P2772535D	12.0	9.0	P2772549D	12.0	9.0	P2772563D	12.0	9.0	P2772573D	
M18+M19	M18+M19	-										14.0	11.0	P2772536D	14.0	11.0	P2772550D	14.0	11.0	P2772564D	14.0	11.0	P2772574D	
M20+M21	M20+M21	-										16.0	12.0	P2772537D	16.0	12.0	P2772551D	16.0	12.0	P2772565D	16.0	12.0	P2772575D	
M22-M26	M22-M26	-																18.0	14.5	P2772566D	18.0	14.5	P2772576D	
M27+M28	M27+M28	-																20.0	16.0	P2772567D	20.0	16.0	P2772577D	
M29-M32	M29-M32	-																22.0	18.0	P2772568D	22.0	18.0	P2772578D	
M33	M33	-																			25.0	20.0	P2772579D	
M34-M38	M34-M38	-																				28.0	22.0	P2772580D
M39-M42	M39-M42	-																				32.0	24.0	P2772581D

► Inch type collets available.

TOOLING SYSTEM

HYDRAULIC CHUCK

SHRINK FIT HOLDER

ER COLLET CHUCK

END MILL HOLDER & SIDE LOCK ARBOR

SHELL MILL ARBOR

POWER MILLING CHUCK

MORSE TAPER ARBOR

SK SLIM CHUCK

SYNCHRO TAPPING CHUCK

ONE STEP TAPPING CHUCK

TAPPING ER CHUCK

TAPPING CHUCK

FACE MILL ARBOR

COPY MILL ARBOR & INDEXABLE DRILL HOLDER

NC DRILL CHUCK & OTHER TOOL HOLDERS

BORING SYSTEM

ACCESSORY & OTHERS



Global Cutting Tool Leader **YG-1**

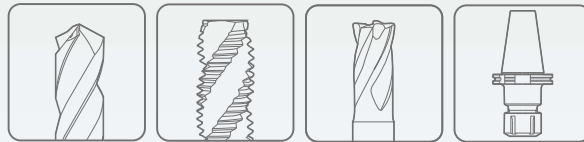



# YG-1 CO., LTD.

## HEAD OFFICE

13-40, Songdogwahak-ro 16beon-gil, Yeonsu-gu, Incheon 21984, South Korea

**Notice** YG-1 Global head office is relocating from December 2020 to a new address as above;

Phone: +82-32-526-0909

<https://www.yg1.kr> E-mail: [yg1@yg1.kr](mailto:yg1@yg1.kr)

**Note** The information is provided for reference only. Tool specifications are subject to change without prior notice. Although we endeavor to supply accurate and timely information, there can be no guarantee to cover every particular application. YG-1 or publishers are not liable for any damage for use of the information.



Search 'YG-1' on social media outlets